



# HARNESS TECHNICAL GUIDE

Gen 1, 2, 3, 4X Coyote / Aluminator 5.0L, 5.2 L  
Godzilla 7.3L

**1967-1972 FORD  
TRANSMISSION 10R80, 10R140**



# CONTENTS

INTRODUCTION	5
AVAILABLE ADD-ONS	5
Option C - Connector Kit	6
Option S - Switch Kit	8
Option PC - Power Center Kit	8
TOOL REQUIREMENTS	9
Option T - Tool Kit	9
BODY GROUNDS	10
Improper Crimping	10
Cleanliness & Metal to Metal Contact	11
Improper Material Selections and Galvanic Corrosion	12
Inadequate Weather Sealing	13
Circuit Overload (Heat) with High Resistivity	13
Fuse Blocks	14
Terminating Unused Wires	15
FRONT SUB-HARNESS	15
Front Bulkhead - Pinout	16
Right Branch Connections	17
Head Light	17
Turn, DRL and Park/Marker Lamps	18
Left Branch Connections	18
Head Light	19
Turn, DRL and Park/Marker Lamps	19
Horn Branch Connection	19
Supercharger Cooler Branch Connection	20



# CONTENTS

MAP Branch Connections	20
Engine Branch Connections	21
Fuel Branch	22
CAB HARNESS	23
Left Door Branch Connections	25
Right Door Branch Connections	25
Dome Branch	26
Clutch Switch Branch	27
Dimmer Switch Branch	28
Headlight Switch Branch	29
Ignition Switch Branch	30
Wiper Switch Branch	31
Exhaust Cutouts Branch	31
Auxiliary Lighting Branch	32
Power Point Branch	33
Radio Branch	33
Brake Switch Branch	34
E-Brake Switch Branch	34
Steering Column Branch	35
Ground Bar Branch	37
Coach Driver Branch	38
Coach Passenger Branch	40
DD Branch - Dakota Digital RTX	42
DD Branch - Tach Adapter	44
DD Branch - Dakota Digital GPS-50-2 Speed Module	45



# CONTENTS

PTS Branch - Push to Start Relay Module	46
PTS Branch - Gear Module	47
PTS Branch - RestoMod Module	48
Front Bulkhead Branch - Pinout	49
Rear Bulkhead - Pinout	50
REAR SUB-HARNESS	51
Right Branch Connections	52
Left Branch Connections	53
Fuel Branch	54
Gear Branch	54
Exhaust Branch 1 and 2	55
Rear Bulkhead Branch - Pinout	56
WARRANTY	58

**PLEASE TAKE A MOMENT TO READ THROUGH THE WARNING DOCUMENT  
BEFORE STARTING INSTALLATION**

## **Terms used in this document:**

**Split** - where a branch comes off the main harness

**Branch** - an offshoot of wires from the main harness

**Pigtail** - short branch of wires, specifically where wires connect externally

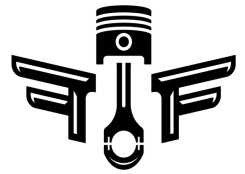

# INTRODUCTION

Thank you for purchasing the 1967-72 Ford Truck Wiring Harness. After years of dedication to the design and development of full turn-key classic truck builds, Fat Fender Garage (FFG) is now offering our high-quality wire harness to fellow enthusiasts and shop professionals.

FFG prioritizes upfront engineering that ensures our harnesses are easy to install in your classic vehicle while maintaining a clean design and top-notch quality.

Our engineers developed this harness to flawlessly fit our custom designs by utilizing industry leading components as well as reliably developed electronic modules and gauges specific to the 1967-72 Ford truck series.

Whether you are using OEM or modern parts, our harness is engineered for flexibility. This design allows for repurposing circuits to meet your specific needs.

## AVAILABLE ADD-ONS

Not all builders are the same, this is why FFG has added 5 optional kits for the 1967-72 Ford truck harness to make wiring your classic truck easier.

- |                                 |                                 |
|---------------------------------|---------------------------------|
| • Option C - Connector Kit      | Part No. - FFG-F6772-WH-CntKit  |
| • Option S - Switch Kit         | Part No. - FFG-F6772-WH-SwKit   |
| • Option T - Crimp Tool Kit     | Part No. - FFG-F6772-WH-CrmpKIT |
| • Option G - Mounting Plate Kit | Part No. - FFG-F6772-WH-MPKIT   |
| • Option PC - Power Center Kit  | Part No. - FFG-F6772-WH-PCKIT   |

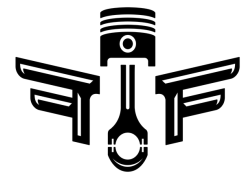

## OPTION C - CONNECTOR KIT

Includes connectors for front, cab and rear sub-harnesses.

### COMMON ITEMS

ITEM 1 QTY: 300



Heat Shrink Tubing Kit  
1/8"x 1"

ITEM A QTY: 52



#8 Ring Terminals

ITEM B QTY: 26



Male Bullet Connector

ITEM C QTY: 26



Female Bullet Connector

ITEM D QTY: 46



Butt Connector 18 AWG

ITEM E QTY: 55



Butt Connector 16 AWG

ITEM F QTY: 20



Fully Insulated Push On Terminals

ITEM G QTY: 40



Ferrule

### FRONT SUB-HARNESS

ITEM H QTY: 2



Headlight - Pigtail Kit

ITEM J QTY: 2



Turn & Park Light -  
Metri-Pack 150 Sealed  
6 Pin Connector

ITEM K QTY: 1



Ford F-150 Horn  
Pigtail

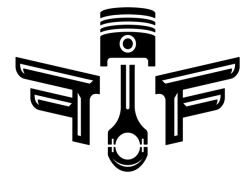

# OPTION C - CONNECTOR KIT

## CAB HARNESS

ITEM L QTY: 1



Headlight, Wiper, Dimmer,  
Brake, Ignition Connector

ITEM M QTY: 30



Packard 56 Series  
Female Terminals

ITEM N QTY: 1



Steering Column  
Flaming River Connector

ITEM O QTY: 1



Ignition Switch Pigtail -  
Includes Heat Shrink and  
Butt Connectors

## REAR SUB-HARNESS

ITEM P QTY: 2



Tail/Turn/ Park - Metri-Pack  
150 Sealed 6 Pin Connector

ITEM Q QTY: 1



Fuel Split Connector

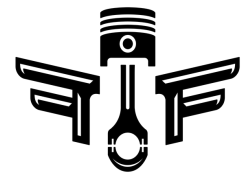

## OPTION S - SWITCH KIT

This kit includes common connectors for the internal cab sub-harnesses.

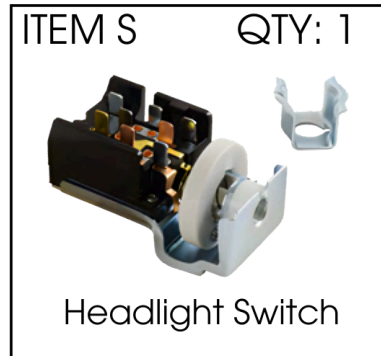
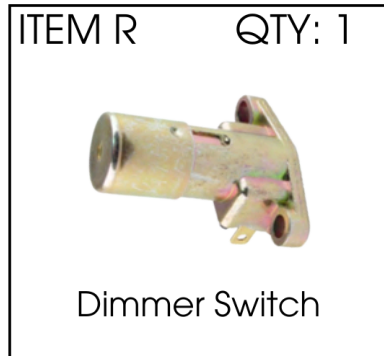

## OPTION PC - POWER CENTER KIT

This kit includes the FFG used and recommended Coach Control, Coupe 23 power center and a separate relay switch harness. The wire harness has two separate pigtails, one to run on the left side of the power center and one to run to the right side of the power center. Should you choose to use a different power center or fuse panel, the harness may still be used if the installer adheres to proper system design and circuit load specific noted in this installation guide.

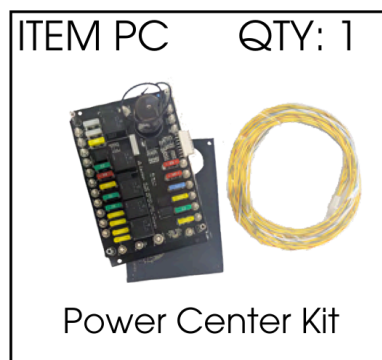

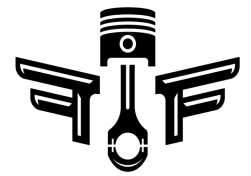

# TOOL REQUIREMENTS





The FFG harness kit greatly reduces the time required to wire your vehicle. The previously mentioned optional connector kit includes common connectors to aid in wiring the items in your build.

In many cases, you will need to crimp wires to various connector contacts. Wire crimping must be done with the proper tools to ensure connections are safe and high quality.

FFG offers an optional Tool Kit with reliable crimp tools to assist in making these strong connections in your unique build.

## OPTION T - TOOL KIT

This kit includes 5 of the most common crimp tools builders use.

<p>ITEM X QTY: 1</p>  <p>Insulated Barrel Crimper</p>	<p>Crimp wires for closed end terminal contacts with an outer insulation at wire connection.</p>	<p>ITEM Y QTY: 1</p>  <p>Packard Series Crimp Tool</p>	<p>Crimps terminal contacts with twin lock terminals for both male and female contacts. Common contacts for OEM pigtails on the 67-72 Ford trucks.</p>
<p>ITEM Z QTY: 1</p>  <p>Open Barrel Crimper</p>	<p>Connects terminal contacts containing an open barrel with small blades that form around the wire and insulation when crimped.</p>	<p>ITEM AA QTY: 1</p>  <p>Metri-Pack 150 Crimp Tool</p>	<p>Properly crimps the three barbs, holding the wire in place and crimping the wire jacket and weather seal to provide a weather seal around each wire.</p>
<p>ITEM BB QTY: 1</p>  <p>Wire Ferrule Crimper</p>		<p>For terminal block wire connections. The wire pass through the ferrule and is crimped on the barrel where the screw terminal clamps on to.</p>	



# BODY GROUNDS

Good body grounds are imperative to any electrical project, to ensure the system functions correctly and with longevity. Often well-meaning installers complete a project; works great upon delivery, only to find over time, electrical anomalies creep in wrecking havoc on a client's custom build. Most times the harness manufacture is blamed for quality issues when, in fact, trouble resides with inadequate grounding work.

The fix to these issues align with an understanding of how good body ground connections, hold for long term reliability to keep your vehicle rolling down the road for years to come. Here are a few enemies to body grounds that every installer should consider when working with automotive electrical systems.

Don't let this become your future!



## Improper Crimping

As previously mentioned, making proper wire connections to terminals/ contacts is imperative and is always done best using the correct tools for the required crimping need.

**If you are not certain of your ability to make proper crimp connections, please seek professional advice to ensure trouble-free installation.**

Here are three examples of poor ground connections with improper heat shrink, metal-to-metal contact, insufficient fasteners, lack of dielectric grease and weather proofing.





Good crimp example.

1. Notice the insulation crimp does not pierce the wire insulation but holds it nicely. Also, note there is plenty of insulation for it to grab.
2. The conductor/wire is extended slightly past the wire crimp.
3. The terminal is not distorted.
4. The conductor/wire crimp has a Bell Mouth on the top edge closest to the insulator.

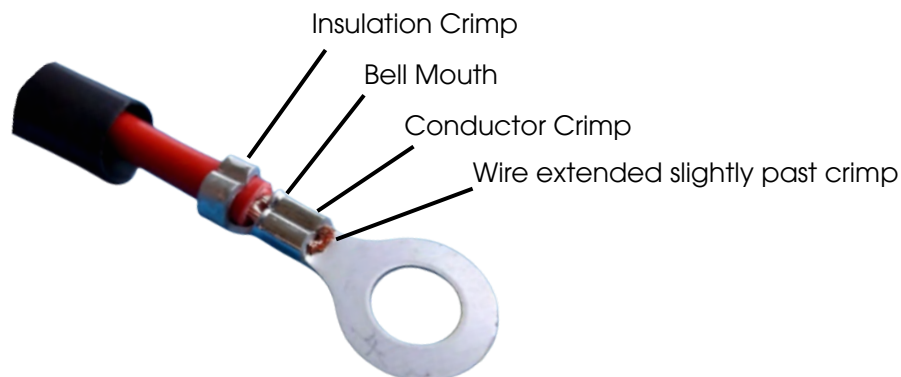

## Cleanliness & Metal to Metal Contact

Metal to metal connection between a connector and a ground is crucial to ensure proper bonding. When installing, ensure contact points are free of rust, corrosion, grease or any other contamination. A common mistake is attaching a connector to a ground point that is painted. A painted surface prevents metal-to-metal contact.

Even if contact is made it may be superficial and not provide enough metal-to-metal surface contact to support the circuit load. This mistake raises the resistance of the connections which leads to a voltage drop, increased current, and increased temperature, a perfect recipe for issues.

Please prepare connector surfaces by removing paint & primer down to metal ensuring a low resistance connection with ring terminals or cable eyelets.



Example of a good metal-to-metal contact strategy.



- An inside or outside star washer is used between the connector and the metal frame surface. The star washer gives bite into the connector and the mounting surface
- The fastener is properly sized for the connector hole being as large as possible.
- The fastener has a wide contact surface with the top of the connector. A properly sized washer would be equivalent.

**IMPORTANT NOTE:** The heat shrink in the image should cover the end of the crimp to weather-proof the wire conductor. It should not extend too far as to interfere with the fastener-to-connector contact.

## Improper Material Selections and Galvanic Corrosion

For dissimilar metal connections like a ring terminal connected to a frame rail, use of tin coated connectors provides excellent corrosion resistance, particularly against moisture and saltwater.

Galvanic corrosion is an electrochemical process where two different metals in electrical contact with an electrolyte, like moisture, corrode preferentially. This process causes for less noble metal to corrode faster, while the more noble metal is protected. This can cause unexpected and destructive connector failures if not accounted for.

Using a tin coated connector and dielectric grease will greatly reduce corrosion.

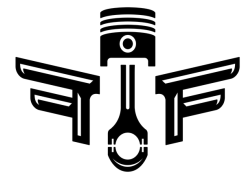

## Inadequate Weather Sealing

Proper weather sealing is a must to keep corrosion away from electrical connection points. The picture below shows rust ingress in the connection. Poor material choice and lack of dielectric grease could well have been the cause.



FFG carefully evaluated various bulkhead connectors and chose connectors that include high quality, built-in weather seals for each wire in the bulkhead connector.

## Circuit Overload (Heat) with High Resistivity

As discussed, many things lead to poor body ground connections. The overall result leads to higher circuit resistance. It's important to understand higher connection resistance, whatever the cause, leads to voltage drops. When voltage drops other components in a system may draw more current resulting in components failures.

Overloading circuits can also occur when the current demand exceeds wire gauge or termination/contact ratings. It's important installers pay close attention to the current rating listed for each wire within this harness.

Don't be this guy!



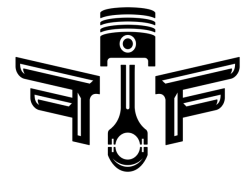

## Fuse Blocks

A common area of circuit overload is the automotive fuse block. The FFG harness is designed with Coach Control fuse blocks in mind. All FFG circuits which connect to the Coach Control are designed with current draws that match the individual circuit fuses in the Coach Control with proper circuit derating for continuous loads with varying wire length.

### IMPORTANT NOTE:

- Ring terminals are sized properly for the stud.
- Heat Shrink is used to insulate the crimp completely covering it.

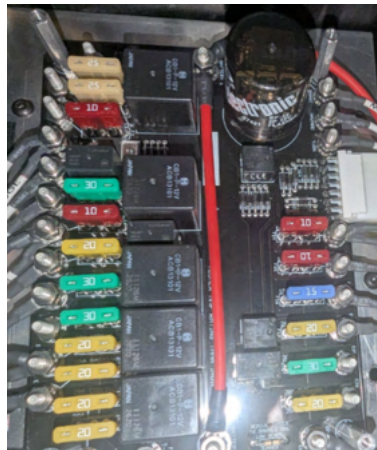

FFG RECOMMENDATION: Rather than stripping a wire, placing in the terminal block and tightening the set screw directly on the wire, we use pin terminals crimped on each wire. The pin terminal includes insulation around the crimp so the risk of stray wires coming in contact with adjacent terminal contacts is all but eliminated.

OK, But....



Preferred for Long Term Reliability



Wire Ferrule

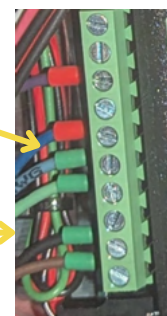



## Terminating Unused Wires

Since the FFG harness design accommodates many different features and possible module connections, not all wires will be used in various builds. To ensure there are no short circuits in your build, be sure to terminate unused wire ends with heat shrink or other suitable means.



## FRONT SUB-HARNESS

The front sub-harness design uses a bulkhead connector by TE Connectivity with Deutsch contacts. With the turn of a ring at this connector, the front harness is easily disconnected for serviceability.

The bulkhead connector has 31 contacts. The front sub-harness comes with the connector, terminations/contacts and seals completely assembled. It is also equipped with eight pigtail splits allowing the builder to run wire groups as needed. The bulkhead connector is located on the passenger side firewall.

The main section of the wire harness runs from the bulkhead connector along the right front chassis rail to the front of chassis. From there the harness tees, the left branch going to the left headlight assembly and right to the right headlight assembly.

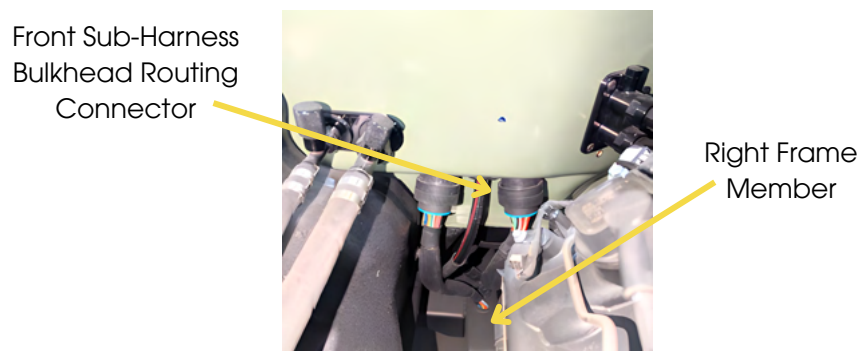

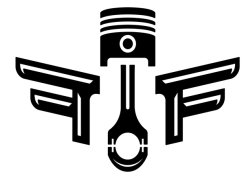

# Front Bulkhead - Pinout

PIN	CIRCUIT	LABEL	I/O	WIRE COLOR	AWG	CIRCUIT CURRENT RATING	FUSE NAME	FUSE VALUE
1	Right Front Headlight High Beam	RF HD HB	0	LIGHT GREEN	16	12A	HIGH BEAM	30A
2	Right Front Headlight Low Beam	RF HD LB	0	TAN	16	12A	LOW BEAM	20A
3	Right Front Turn Signal	RF TURN	0	DARK BLUE	16	12A	FLASHER	15A
4	Front Parking/Marker Lights	MARKER	0	BROWN	16	12A	HDLGHT SW	15A
5	Auxiliary Lighting	AUX	0	ORANGE	16	12A	RADIO/AMP	20A
6	Auxiliary Lighting Ground	AUX GND1	0	BLACK	16	12A	N/A	N/A
7	Horn	HORN	0	DARK GREEN	16	12A	HORN	20A
8	Left Front High Beam	LF HD HB	0	LIGHT GREEN	16	12A	HIGH BEAM	20A
9	Left Front Low Beam	LF HD LB	0	TAN	16	12A	LOW BEAM	20A
10	Daytime Running Light	DRL	0	WHITE	16	12A	RADIO/AMP	20A
11	Left Front Turn Signal	LF TURN	0	LIGHT BLUE	16	12A	FLASHER	15A
12	NC							
13	Check Engine Indicator	CEL	I	BLACK	18	8A	N/A	N/A
14	Windshield Wiper Pump	WSHR PMP	0	LIGHT GREEN	16	15A	WIPERS	20A
15	Air Conditioning Clutch	AC CLUTCH	0	YELLOW	16	15A	N/A	N/A
16	Engine Control Pack Ignition Signal	CTL PK IGN	0	PINK	16	12A	IGN/EFI/ECU	30A
17	Engine Start Signal	START REQ	0	VIOLET	16	12A	IGN SW	10A
18	Oil Pressure Sensor Power	OP PWR	0	RED	18	8A	IGN SW	10A
19	Oil Pressure Sensor Ground	OP GND	I	BLACK	18	8A	N/A	N/A
20	Oil Pressure Sensor Signal	OP SIG	I	WHTIE	18	8A	N/A	N/A
21	Tach, Coil Supply Voltage Input	COIL SRC	I	RED	20	5A	N/A	N/A
22	Tach, Coil Supply Voltage Output to Coils	COIL OUT	0	VIOLET	20	5A	N/A	N/A
23	Tach, Cable Drain Wire for Shielding	COIL SHLD	I	BARE	20	5A	N/A	N/A
24	Cylinder Head Temperature Sensor Signal	C TEMP	I	YELLOW	18	8A	N/A	N/A
25	Cylinder Head Temperature Sensor Ground	C TEMP GND	0	BLACK	18	8A	N/A	N/A
26	NC							
27	NC							
28	Fuel Pressure Sensor Ground	FL PR BLK	0	BLACK	18	8A	N/A	N/A

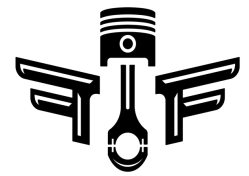

## Front Bulkhead - Pinout

PIN	CIRCUIT	LABEL	I/O	WIRE COLOR	AWG	CIRCUIT CURRENT RATING	FUSE NAME	FUSE VALUE
29	Fuel Pressure Sensor Power	FL PR GRAY	0	GRAY	18	8A	VAPOR WORKS	VARIES
30	Fuel Pressure Sensor Signal	FL PR BRN	I	BROWN	18	8A	VAPOR WORKS	VARIES
31	Supercharger Cooler	SC IGN	0	PINK	16	12A	IGN/EFI/ECU	25A

## Right Branch Connections

The right harness split powers the right headlight, parking/marker lights, daytime running lights and right turn signal. If you purchased the connector kit you will need to add connectors as followed on the next page.

CIRCUIT	CIRCUIT LABEL	WIRE COLOR	AWG	CURRENT RATING	FUSE NAME	FUSE VALUE
Right Headlight High Beam	RT HD HB	LIGHT GREEN	16	12A	HIGH BEAM	30A
Right Headlight Low Beam	RT HD LB	TAN	16	12A	LOW BEAM	20A
Right Daytime Running Light	DRL	WHITE	16	6A*	RADIO/AMP	20A
Left Daytime Running Light Tie-in	DRL	WHITE	16	6A*	RADIO/AMP	20A
Right Turn Signal	RT TURN	DARK BLUE	16	12A	FLASHER	15A
Right Marker	MARKER	BROWN	16	6A**	LOW BEAM	20A
Left Marker Tie-in	MARKER	BROWN	16	6A**	LOW BEAM	20A
Right Headlight Assembly Ground	RF HD GND	BLACK	16	21A	N/A	N/A

\*The left and right DRL share the same conductor from the bulkhead connector, thus each DRL is rated for 6A.

\*\*The left and right Marker/Parking share the same conductor from the bulkhead connector, thus each Parking and Marker are rated for 6A.

## Head Light

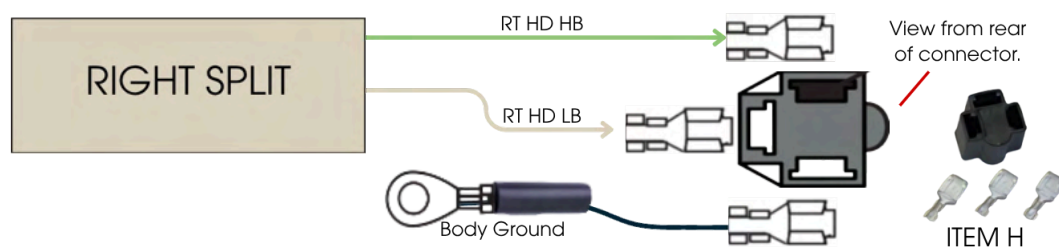

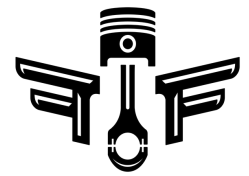

## Turn, DRL and Park/Marker Lamps

Both the DRL and the Marker signals have two conductors. Both conductors marked DRL are crimped into one contact and likewise for the marker signal. If needed load resistors for LED lights can be added by installer and tied into the grounding ring terminal.

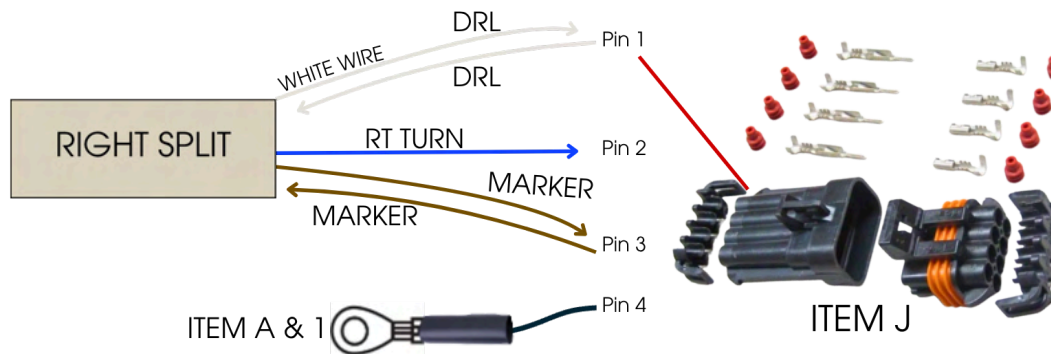

### TESTING Passenger Headlight Assembly

- Low beam                       Parking lights                       Turn signal  
 High beam                       Marker lights (if present)

## Left Branch Connections

The left harness branch powers the left headlight, parking/marker, daytime running lights and left turn signal.

CIRCUIT	CIRCUIT LABEL	WIRE COLOR	AWG	CURRENT RATING	FUSE NAME	FUSE VALUE
Left Headlight High Beam	LF HD HB	LIGHT GREEN	16	12A	HIGH BEAM	30A
Left Headlight Low Beam	LF HD LB	TAN	16	12A	LOW BEAM	20A
Left Daytime Running Light	DRL	WHITE	16	6A*	RADIO/AMP	20A
Left Turn Signal	LF TURN	LIGHT BLUE	16	12A	FLASHER	15A
Left Marker	MARKER	BROWN	16	6A**	LOW BEAM	20A
Left Headlight Assembly Ground	LF HD GND	BLACK	16	21A	N/A	N/A

\*The left and right DRL share the same conductor from the bulkhead connector, thus each DRL is rated for 6A.

\*\*The left and right Parking and Marker share the same conductor from the bulkhead connector, thus each Parking and Marker are rated for 6A.

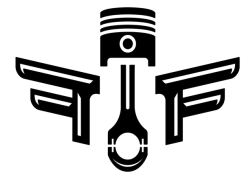

## Head Light

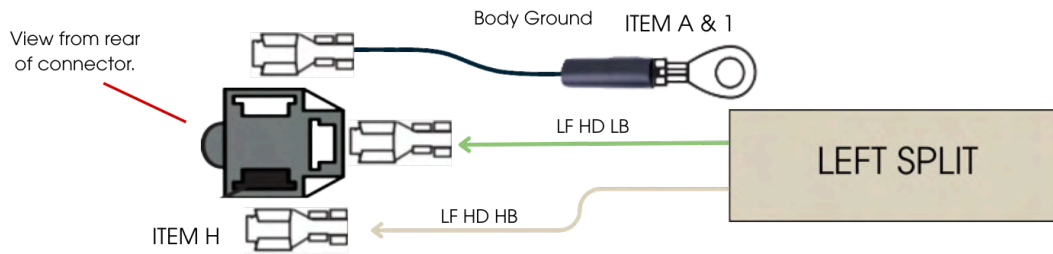

## Turn, DRL and Park/Marker Lamps

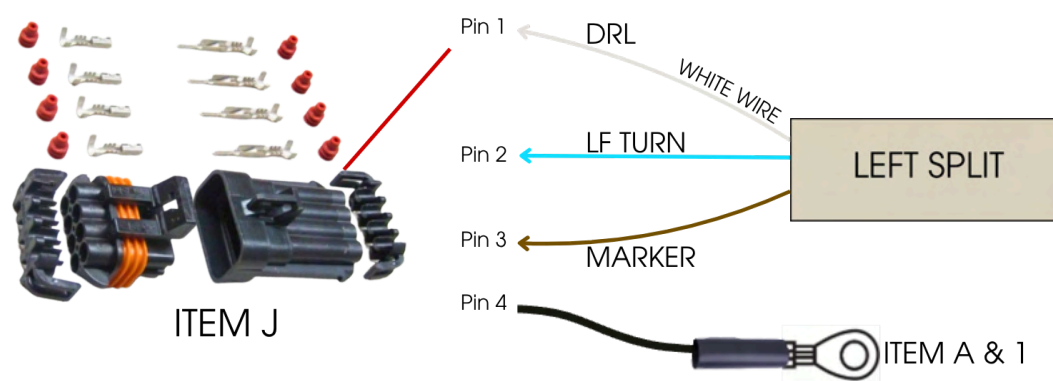

### TESTING Driver Headlight Assembly

- Low beam
- High beam
- Parking lights
- Marker lights (if present)
- Turn signal

## Horn Branch Connection

The horn harness split circuits power the horn and auxiliary lighting.

CIRCUIT	CIRCUIT LABEL	WIRE COLOR	AWG	CURRENT RATING	FUSE NAME	FUSE VALUE
Auxiliary Accent Lighting	AUX	ORANGE	16	12A*	RADIO/AMP	20A
Auxiliary Accent Lighting GND	AUX GND	BLACK	16	12A*	N/A	N/A
Horn	HORN	DARK GREEN	16	12A	HORN	20A

\*If the auxiliary accent lighting circuit is used for a light bar, please consider that many light bars exceed the current rating of 12A. Please ensure all combined auxiliary light sources do not exceed this listed current rating. If the planned current load is greater than 12A please use this circuit to trigger an external relay.

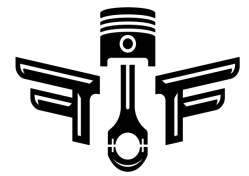

## Horn Branch Connection

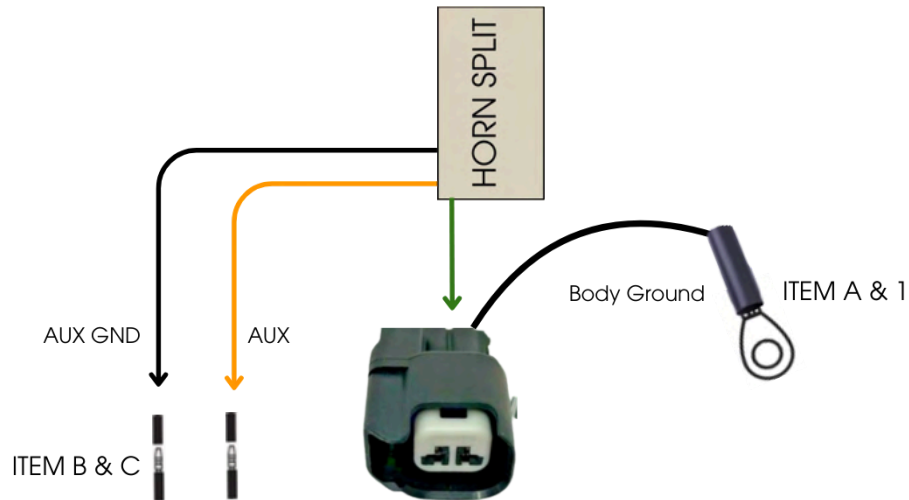

### TESTING Horn Assembly

- Horn turns on/off with steering horn ring
- Aux lights

## Supercharger Cooler Branch Connections

CIRCUIT	CIRCUIT LABEL	WIRE COLOR	AWG	CIRCUIT CURRENT RATING	FUSE NAME	FUSE VALUE
Supercharger Cooler	SC IGN	PINK	16	12A	IGN/EFI/ECU	25A

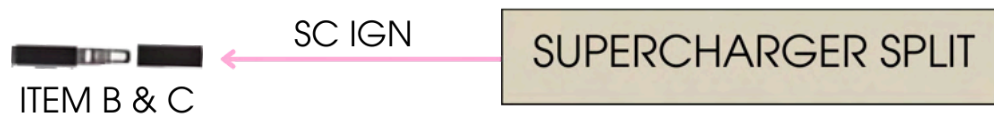

### TESTING Super Charger

- Super Charger cooling power

## MAP Branch Connections

CIRCUIT	CIRCUIT LABEL	WIRE COLOR	AWG	CIRCUIT CURRENT RATING	FUSE NAME	FUSE VALUE
Map Sensor - 5V Reference	MAP ORNG	ORANGE	18	6A	VAPOR WORKS	Varies
Map Sensor - Low Reference	MAP LT GREEN	LIGHT GREEN	18	6A	N/A	N/A
Map Sensor - Map Signal	MAP GRAY	GRAY	18	6A	N/A	N/A



## MAP Branch Connections

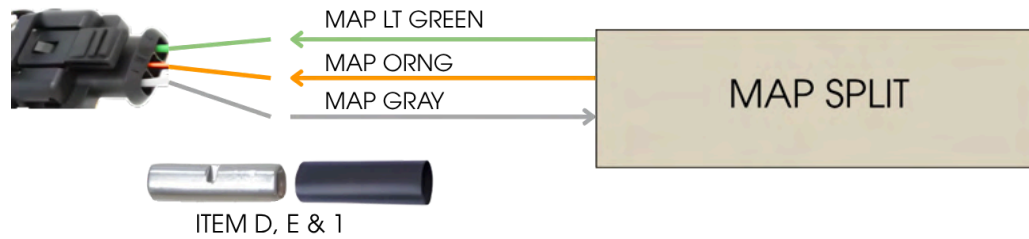

### TESTING Map Branch

- Map signal

## Engine Branch Connections

Due to a variety of engine configurations, the installer must determine the best place to make these connections. Enough length is included to accomodate flexible locations. COIL SRC and OUT wire color may differ.

CIRCUIT	CIRCUIT LABEL	WIRE COLOR	AWG	CIRCUIT CURRENT RATING	FUSE NAME	FUSE VALUE
Washer Motor	WASHER	DARK GREEN	16	12A	WIPERS	20A
Air Conditioning Clutch (from fuse panel)	AC CLUTCH	YELLOW	16	12A	N/A	N/A
Ford Control Pack Ignition Switch (to control pack)	CTL PK IGN	PINK	16	12A	IGN/EFI/ECU	25A
Oil Pressure Power Lead (from Dakota Digital)	OP PWR	RED	18	6A	IGN SW	10A
Oil Pressure Ground (from Dakota Digital)	OP GND	BLACK	18	6A	N/A	N/A
Oil Pressure Signal (to Dakota Digital)	OP SIG	WHITE	18	6A	N/A	N/A
Fuel Pump Enable (from Control Pack)	FUEL EN	LIGHT GREEN	16	12A	N/A	N/A
Coil Voltage Source (from Coils Supply Voltage to Tach Adapter)	COIL SRC	RED or YELLOW	20	4A	N/A	N/A
Coil Voltage Output (from Tach Adapter to coils)	COIL OUT	VIOLET or GREEN	20	4A	N/A	N/A
Coil Cable Shield (cable shield connected to ground at Dakota Digital)	COIL SHLD	BARE	20	4A	N/A	N/A
Coolant Temperature Reference V (from sensor to Dakota Digital)	C TEMP	YELLOW	18	6A	N/A	N/A
Coolant Temperature Ground (from sensor to Dakota Digital)	C TEMP GND	BLACK	18	6A	N/A	N/A

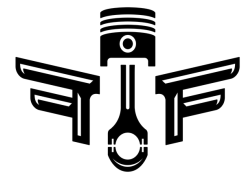

## Engine Branch Connections

CIRCUIT	CIRCUIT LABEL	WIRE COLOR	AWG	CIRCUIT CURRENT RATING	FUSE NAME	FUSE VALUE
Check Engine (from engine control pack to Dakota Digital)	CEL	BLACK	18	6A	N/A	N/A
Engine Start Request Signal	START REQ	VIOLET	16	12A	IGN SW	10A

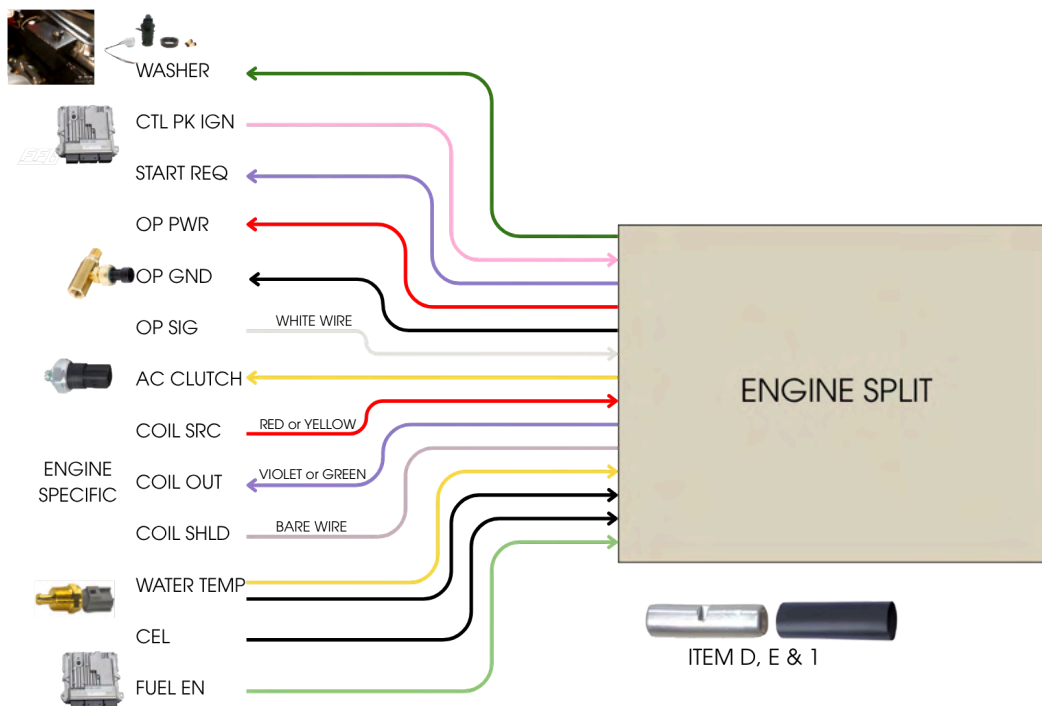

### TESTING Engine

- |   |  |
|---|--|
| <input type="checkbox"/> Start request                            | <input type="checkbox"/> Oil pressure signal         |
| <input type="checkbox"/> AC clutch                                | <input type="checkbox"/> Fuel enable                 |
| <input type="checkbox"/> Engine coolant temperature               | <input type="checkbox"/> Control pack ignition power |
| <input type="checkbox"/> Tach functionality with coil connections |  |

## Fuel Branch

This harness branch is for a Vapor Worx fuel control module. The Vapor Worx module BW4B Ford fuel module is designed for return-less fuel systems, utilizing a pulse-width-modulated (PWM) controller which varies the fuel delivery based on demand. If you are interested in purchasing this module please contact our sales department for proper ordering information. The FFG harness accommodates wiring for a required 3 wire map sensor located in the engine bay. Also, included are circuits for fuel pressure monitoring routed through the rear sub-harness to the fuel pump.



## Fuel Branch

CIRCUIT	CIRCUIT LABEL	WIRE COLOR	AWG	CIRCUIT CURRENT RATING	FUSE NAME	FUSE VALUE
Fuel pressure sensor +5V	FL PR GRAY	GRAY	18	8A	N/A	N/A
Fuel pressure sensor gnd	FL PR BLK	BLACK	18	8A	N/A	N/A
Fuel pressure sensor signal	FL PR BRN	BROWN	18	8A	N/A	N/A
Fuel pump enable signal	FUEL EN	LIGHT GREEN	16	15A	N/A	N/A
Map sensor +5V	MAP ORNG	ORANGE	18	8A	N/A	N/A
Map sensor gnd	MAP LT GREEN	LIGHT GREEN	18	8A	N/A	N/A
Map sensor signal	MAP GRAY	GRAY	18	8A	N/A	N/A

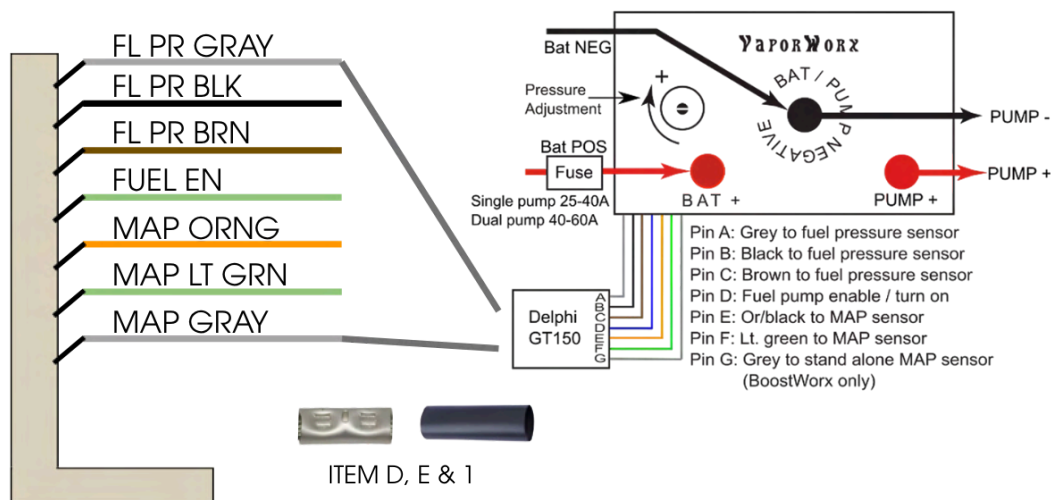

### TESTING Fuel Branch

- Map signal
  Fuel pressure
  Fuel enable

## CAB HARNESS

The cab harness is equipped with a thru-panel bulkhead connector by TE Connectivity with Deutsch contacts. There's two bulkhead connectors, one for the front section beyond the cab and one for the rear section to the bed. Both are located on the right side of the cab at the right front firewall, out of the way of aftermarket air conditioning.

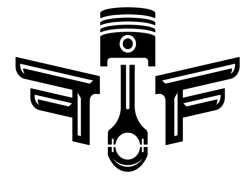

# CAB HARNESS

The thru-panel connector for the front sub-harness has 31 contacts while the rear thru-panel bulkhead has 21 contacts. Both connectors come pre-assembled with all contacts crimped and installed in the connector housing with weather seals. As shown, the bulkhead connectors are mounted on a shelf behind the aftermarket air conditioning units. No real preference which connector is on right or left side.

A wire loom is not used for the front cab harness since weather exposure is not a concern. The cab harness is configured with a central horizontal group of wires that runs the width of the cab in the dash. Branches of wires, often referred to as splits or pigtails, will tee off the main center branch to respective areas in the cab. The pigtails on the harness include extra length to allow installers to mount switches in different locations, if they so choose.

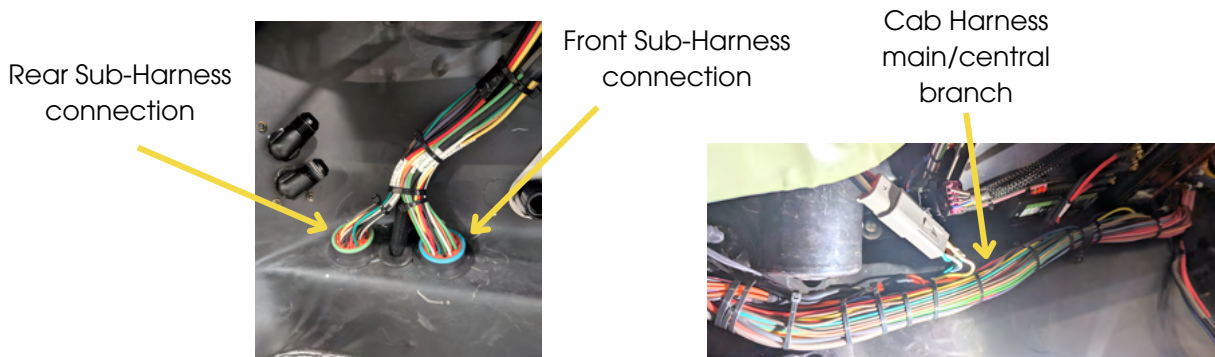

The cab harness has 21 branches (pigtails) off the central harness. Each branch is function specific and located at the approximate location where the pigtail wires will be connected to switches or modules. The branches come with extra length, offering the installer the option of fine tuning the final location, simply cut and add the proper mating connector or termination to the wire and fasten the pigtails to the switch or modules needed. The provided labels are not pre-shrunk so the installer may move the label on the wire to its final location prior to shrinking.

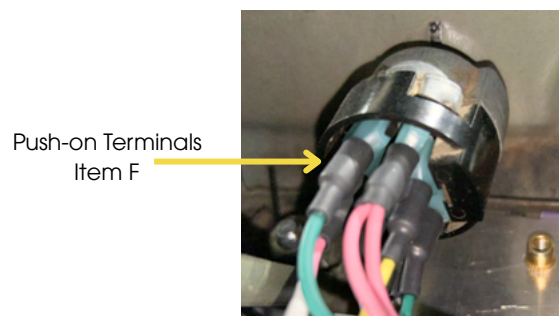

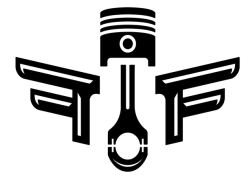

## Left Door Branch Connections

The left door branch powers the left headlight, parking/marker lights, daytime running lights and left turn signal. If you purchased the connector kit, you will need to add connectors as follows;

CIRCUIT	CIRCUIT LABEL	I/O	WIRE COLOR	AWG	CIRCUIT CURRENT RATING	FUSE NAME	FUSE VALUE
Door Pin Switch	DOME SW1	GND	BLACK	18	8A	N/A	N/A
12V for Panel Lighting	LF DR PNL	0	VIOLET	18	8A	HEAT AC	30A*
12V for Power Windows	LF WIN PWR	0	DARK BLUE	16	12A	PWR WINDOWS	30A
12V for Door Locks	DOOR LK PWR	0	ORANGE	16	12A	PWR LOCKS	20A*
Door Lock Trigger	LOCK	I	DARK GREEN	16	12A	N/A	N/A
Door Unlock Trigger	UNLOCK	I	DARK BLUE	16	12A	N/A	N/A
Left Headlight Assembly Ground	LF HD GND	GND	BLACK	16	21A	N/A	N/A

\*Shared with other circuits

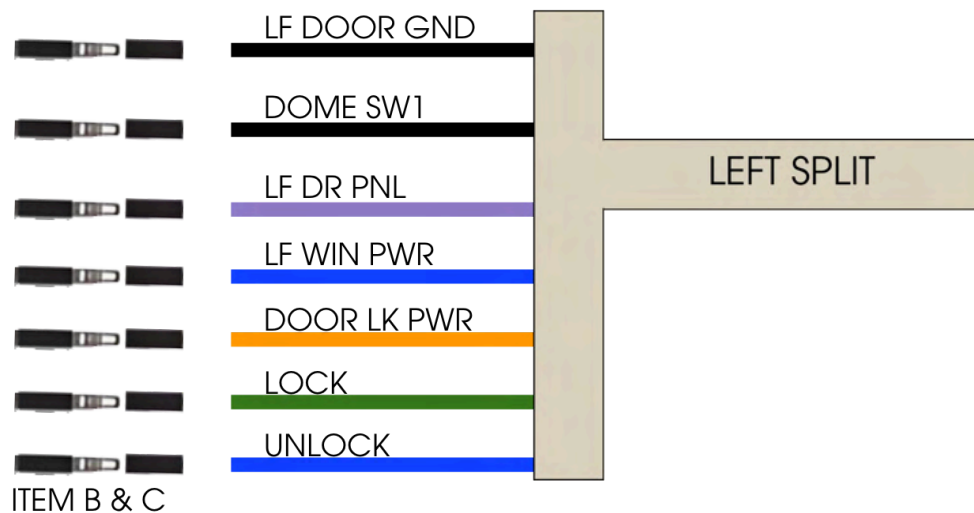

## Right Door Branch Connections

The right door split powers the right headlight, parking/marker lights, daytime running lights and right turn signal. If you purchased the connector kit, you will need to add connectors as follows;

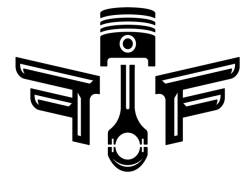

## Right Door Branch Connections

CIRCUIT	CIRCUIT LABEL	I/O	WIRE COLOR	AWG	CIRCUIT CURRENT RATING	FUSE NAME	FUSE VALUE
Door Pin Switch	DOME SW2	GND	BLACK	18	8A	N/A	N/A
Door Pin Switch	DOME SW IND	GND	BLACK	18	8A	N/A	N/A
12V for Panel Lighting	RT DR PNL	0	VIOLET	18	8A	HEAT AC	30A**
12V for Power Windows	RT WIN PWR	0	DARK BLUE	16	12A	PWR WINDOWS	30A
12V for Door Locks	DOOR LK PWR	0	ORANGE	16	12A	PWR LOCKS	20A*
Door Lock Trigger	LOCK	I	DARK GREEN	16	12A	N/A	N/A
Door Unlock Trigger	UNLOCK	I	DARK BLUE	16	12A	N/A	N/A
Right Headlight Assembly Ground	RT HD GND	GND	BLACK	16	21A	N/A	N/A

\*The DOME SW2/DOME SW IND circuits are a daisy chain configuration. These two signals are spliced together and connected to the door pin switch.

\*\*Shared with other circuits

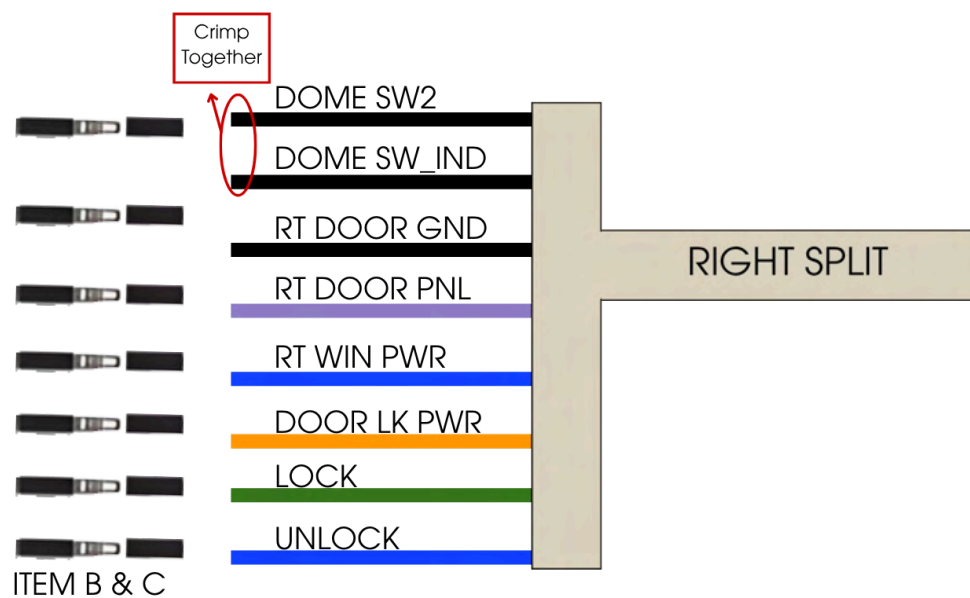

## Dome Branch

The dome light branch accommodates the inside cab dome light. This pigtail has extra length to allow routing to the OEM location just above the back window. The circuit is rated 12 Amps and can power both a passenger compartment light as well as an outside cab light used to light the truck bed as long as the current draw is less than or equal to the circuit rating.

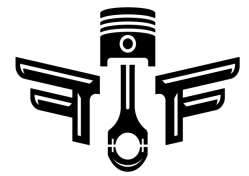

## Dome Branch

CIRCUIT	CIRCUIT LABEL	I/O	WIRE COLOR	AWG	CIRCUIT CURRENT RATING	FUSE NAME	FUSE VALUE
Provides 12V fused power for the interior dome light and bed light, if needed	DOME	0	WHITE	18	8A	CLOCK /DOME	10A
Dome light is ground switched so this signal carries the ground to the dome light; activated by the headlight switch and/or door pin switches	DOME SW GND	GND	BLACK	18	8A	N/A	N/A



### TESTING Dome Light

Left door   
  Right door   
  Headlight

## Clutch Switch Branch

The clutch switch pigtail is meant for manual transmission vehicles. If your vehicle is an automatic, this pigtail will remain unused. It is compatible with OEM or aftermarket clutch interlock switches. It is also compatible with a standard OEM style ignition switch or with push-to-start system.

### IMPORTANT NOTES:

- 1) If your vehicle is automatic the installer should connect the PTS ST SW or START SW to START REQ, thus bypassing the non-existent clutch switch.
- 2) The "PTS ST SW" (Push-to-Start) or "START SW" (START) circuits are independent of each other, only one of the other should ever be used.

CIRCUIT	CIRCUIT LABEL	I/O	WIRE COLOR	AWG	CIRCUIT CURRENT RATING	FUSE NAME	FUSE VALUE
Push to Start trigger; will connect to Start Req when clutch is depressed.	PTS ST SW	I	YELLOW	18	8A	HD LT SW	15A
OEM Style ignition trigger; will connect to Start Req when clutch is depressed.	START SW	0	YELLOW	18	8A	IGN SW	10A
Final signal for engine start, routed to the front harness for connection to your specific ECM.	START REQ	0	VIOLET	18	8A	IGN SW or HD LT SW	10A* or 15A*

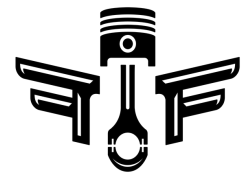

## Clutch Switch Branch



### TESTING Clutch

Engine starts

## Dimmer Switch Branch

The dimmer switch pigtail connects to an OEM style dimmer switch in the lower left driver footwell. The design is flexible if the installer optionally wants to connect this to a steering column headlight switch.

To assist installation, the optional FFG Connector Kit includes an OEM style plug.

CIRCUIT	CIRCUIT LABEL	I/O	WIRE COLOR	AWG	CIRCUIT CURRENT RATING	FUSE NAME	FUSE VALUE
The "HIGH" circuit acts as a trigger for the Coach Works fuse panel to turn on high beam lights via a relay on the Coach Works fuse panel**	HIGH	0	LIGHT GREEN	18	8A	HDLGHT SW	15A*
"HIGH" beam indicator to the Dakota Digital dash control*	HIGH	0	LIGHT GREEN	18	8A	HDLGHT SW	15A*
12V source coming from headlight switch. This signal provides 12V when lights are turned on at the head light switch	DIM SW	I	BROWN	18	8A	HDLGHT SW	15A*
The "LOW" circuit acts as a trigger for the Coach Works panel to turn on low beam lights via a relay on the Coach Works fuse panel**	LOW	0	TAN	18	8A	HDLGHT SW	15A*

\*The extra "HIGH" circuit is an indicator to the Dakota Digital dash control. Both high signals should be tied together.

\*\*These outputs trigger the relay on the Coach control fuse panel and drive directly headlight low or high beams.

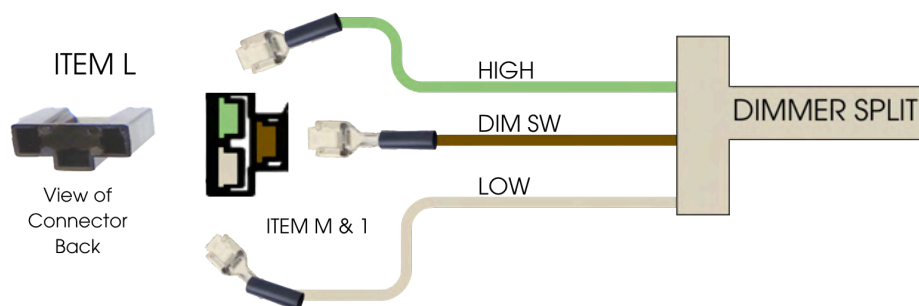

### TESTING Floor Dimmer

Low beam

High beam

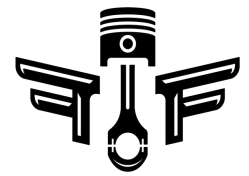

# Headlight Switch Branch

The headlight switch pigtail connects to an OEM style headlight switch using an OEM pigtail connector. The pigtail connector is part of the FFG optional connector kit. The wire connections are made as follows.

CIRCUIT	CIRCUIT LABEL	I/O	WIRE COLOR	AWG	CIRCUIT CURRENT RATING	FUSE NAME	FUSE VALUE
This is the main fused 12V signal to the headlight switch coming from the fuse panel	HD 12V BAT	I	RED	18	8A	HDLGHT SW	15A*
The headlight switch powers directly the parking lights front & rear	F PARK	O	BROWN	16	12A	HDLGHT SW	15A*
	R PARK	O	BROWN	16	12A	HDLGHT SW	15A*
The headlight switch powers directly rear tail lights. A signal from the PTS module is also connected if the user wants the PTS to blink the rear parking lights during lock or unlock.	LIGHT PTS 2	O	BROWN	18	8A	Varies	Varies
	TAIL	O	BROWN	16	12A	HDLGHT SW	15A*
	TAIL	O	BROWN	16	12A	HDLGHT SW	15A*
12V feed to dimmer switch	DM SW	I	BROWN	18	8A	HDLGHT SW	15A*
LF and RT Door pin switch and indicator connections	DOME SW	GND	BLACK	18	8A	N/A	N/A
	DOME SW	GND	BLACK	18	8A	N/A	N/A
	DOME SW	GND	BLACK	18	8A	N/A	N/A

\*All Dome gnd signals are combined together and attach to the headlight switch.

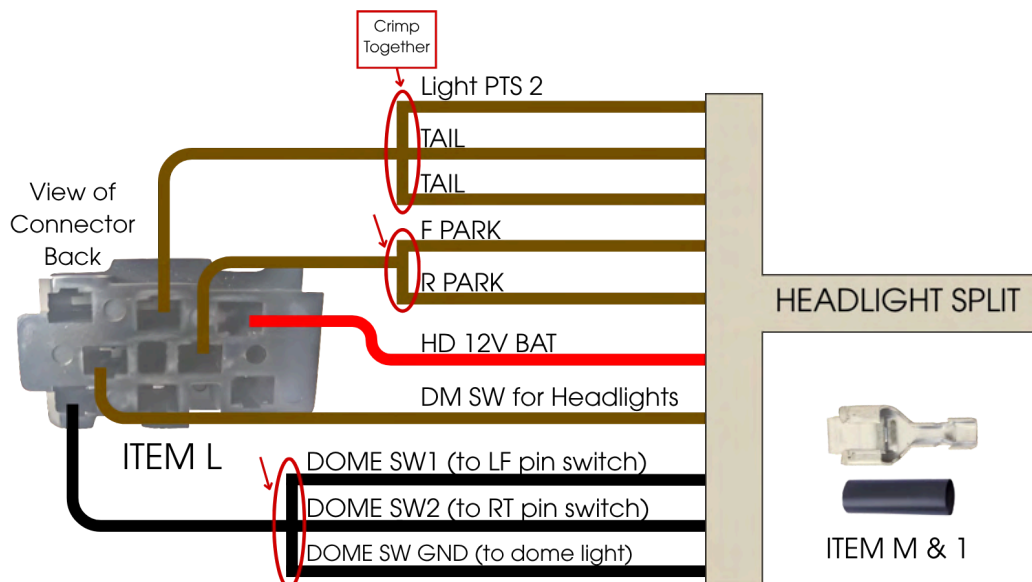

## TESTING Headlight Switch

- Front parking lights
- Dome lights
- Taillights
- Rear parking lights
- Headlights

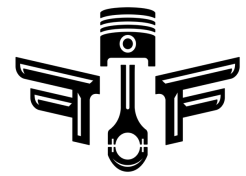

## Ignition Switch Branch

Between 1967 and 1972, three different ignition switch housings were used though this FFG harness will interface with all three ignition housings. For simplicity, FFG prefers the 4-prong connector used in 1967. The mating connector is included in the optional connector kit. The 1970-72 ignition housing may also be installed using push-on connectors included in this wire harness kit.

The 1968-69 ignition housing is more difficult because the housing uses round style connectors. If the installer wants to use this style, the proper pigtail will need to be sourced by the installer and connected to the FFG harness as shown below.

CIRCUIT	CIRCUIT LABEL	I/O	WIRE COLOR	AWG	CIRCUIT CURRENT RATING	FUSE NAME	FUSE VALUE
When the key turns to start this drives either the clutch or may be wired to the Ford control pack	START SW	0	YELLOW	18	8A	IGN SW	10A
Powers all Ignition components	IGN SW	0	PINK	16	12A	IGN SW	10A
Fused 12V battery source	IGN 12V BAT	I	RED	16	12A	IGN SW	10A
Powers Accessory Components	ACC SW	0	ORANGE	16	12A	IGN SW	10A

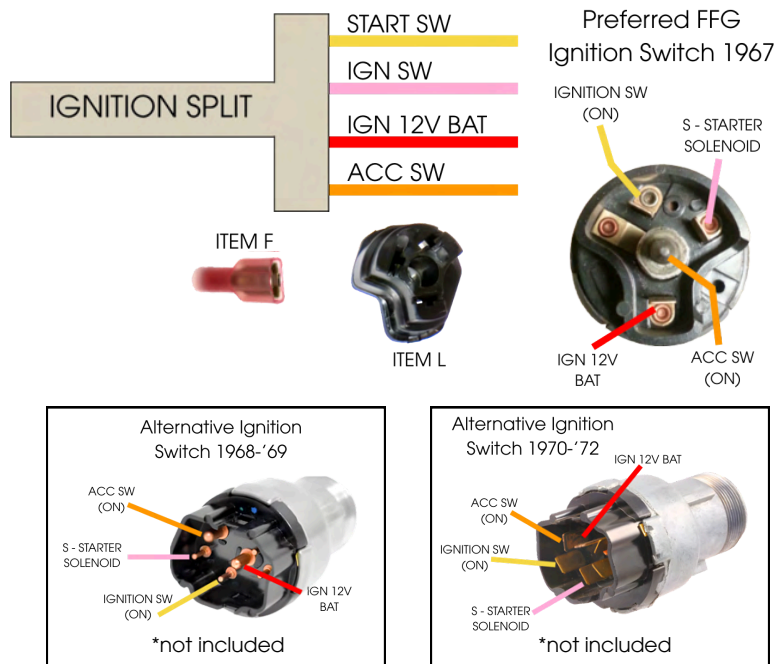

### TESTING Ignition Switch

- Everything off
- Ignition components in IGN position
- Accessories on in ACC position
- Engine starts in START position

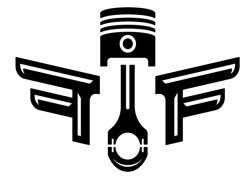

## Wiper Switch Branch

The best solution for a wiper switch is to purchase a kit that provides both the switch as well as the motor. The two signals will provide power to this assembly and connection for a washer pump if desired running to engine compartment.

CIRCUIT	CIRCUIT LABEL	I/O	WIRE COLOR	AWG	CIRCUIT CURRENT RATING	FUSE NAME	FUSE VALUE
Windshield Washer Pump	WSHR PMP	O	LIGHT GREEN	16	12A	WIPERS	20A
Wiper Switch - power input	WIPER IGN	I	PINK	16	12A	WIPERS	20A



### TESTING Wipers

- Wiper low speed
- Wiper high speed (if equipped)
- Washer functions

## Exhaust Cutouts Branch

The FFG harness supports exhaust cutouts. It includes a pigtail at the dash for a switch, based on designer preference, and two pigtails in the rear harness for two individual cutout motors. Cutouts use normal and reverse polarity signals to drive the motor forward and reverse, thus opening and closing the butterfly valve. FFG recommends a three position, DPDT switch with the default position being off.

The switch should be wired such that moving the switch one way will place 12V and ground on EX CUT 1 and 2 respectively while moving the switch the other direction will reverse the polarity placing ground and 12V on EX CUT 1 and 2 respectively.

CIRCUIT	CIRCUIT LABEL	I/O	WIRE COLOR	AWG	CIRCUIT CURRENT RATING	FUSE NAME	FUSE VALUE
Output - Can be +12V or GND	EX CUT 1	O	VIOLET	16	12A	PWR POINT	10A
Output - Always inverse of Ex Cut 1	EX CUT 2	O	BROWN	16	12A	PWR POINT	10A
Input to Switch - +12V	EX CUT	I	PINK	16	12A	PWR POINT	10A
Input to Switch - Ground Signal	EX CUT GND	GND	BLACK	16	12A	N/A	N/A

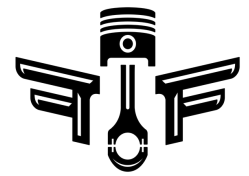

## Exhaust Cutouts Branch



### TESTING Exhaust Cutouts

- Passenger exhaust butterfly       Driver exhaust butterfly

## Auxiliary Lighting Branch

The FFG harness accommodates auxiliary front under-hood, rear truck bed or ground accent lighting and includes a pigtail at the dash for a switch. The circuit runs from the dash to the front under-hood area and to the rear bed area through the front and rear bulkhead connectors.

One switch can be used to control both front and rear lighting together, or two independent switches may be used to control front and rear independently.

**IMPORTANT NOTE:** Ensure that all light source current loads, Front and Rear combined, do not exceed the circuit specification below.

CIRCUIT	CIRCUIT LABEL	I/O	WIRE COLOR	AWG	CIRCUIT CURRENT RATING	FUSE NAME	FUSE VALUE
Aux ACC - Fused 12V input to the switch	AUX ACC	I	ORANGE	16	12A	RADIO	20A
Aux Output - Switched 12V output to the front hood area	AUX	O	ORANGE	16	12A	RADIO	20A
Aux Output - Switch 12V output to the rear bed area	AUX	O	ORANGE	16	12A	RADIO	20A

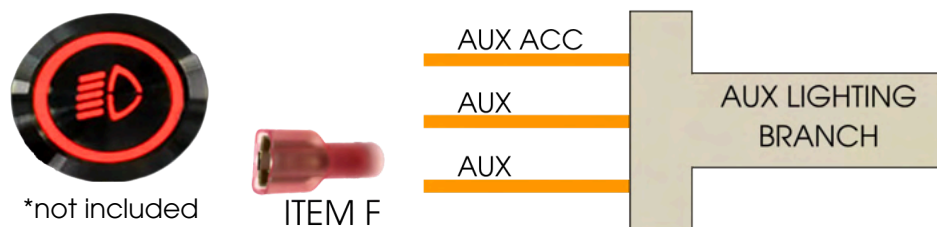

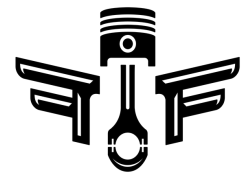

## Power Point Branch

The power point branch provides power to plug-in devices such as cell phones and other USB based devices. There are two wires in the branch along with the current rating. The power rating is limited to 120W at a nominal 12V.

CIRCUIT	CIRCUIT LABEL	I/O	WIRE COLOR	AWG	CIRCUIT CURRENT RATING	FUSE NAME	FUSE VALUE
Power Point Ground - connects to user provided switch.*	PWR POINT GND	GND	BLACK	16	10A,120W	N/A	N/A
Power Point - Fused 12V input- connects to the user provided switch.	PWR POINT	0	PINK	16	10A,120W	PWR POINT	10A

\*FFG recommends that multiple grounds be tied to one dedicated ground bar to reduce potential for ground loops in the system.

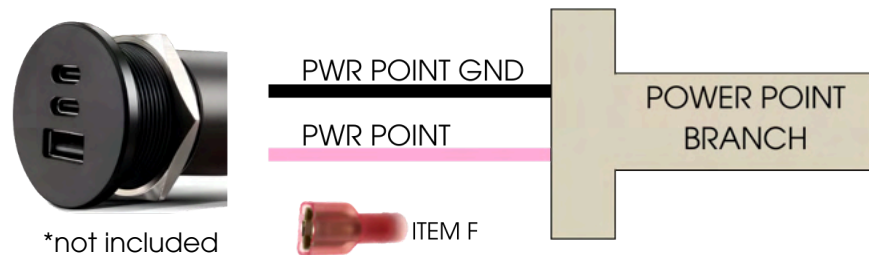

\*not included

### TESTING Power Point

Powered when IGN, ACC or ON position

## Radio Branch

The radio branch includes three connectors;

- 1) Constant 12V source to maintain radio memory,
- 2) Accessory switched 12V sources by the ignition ACC position,
- 3) a dedicated ground signal.

CIRCUIT	CIRCUIT LABEL	I/O	WIRE COLOR	AWG	CIRCUIT CURRENT RATING	FUSE NAME	FUSE VALUE
Radio Ground - Originates from the ground branch.*	RADIO GND	GND	BLACK	16	12A	N/A	N/A
Radio Accessory - Fused 12V input which provides accessory power. Sourced from the ignition accessory on position.	RADIO ACC	0	ORANGE	16	12A	RADIO/AMP	20A
Radio Battery Connection - Constant 12V input, providing a constant 12V signal to maintain internal radio memory settings.	RADIO BATT	0	RED	16	12A	CLOCK/DOME	10A

\*FFG recommends that multiple grounds be tied to one dedicated ground bar to reduce potential for ground loops in the system.

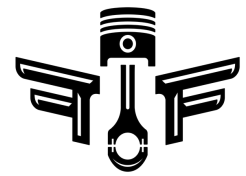

## Radio Branch

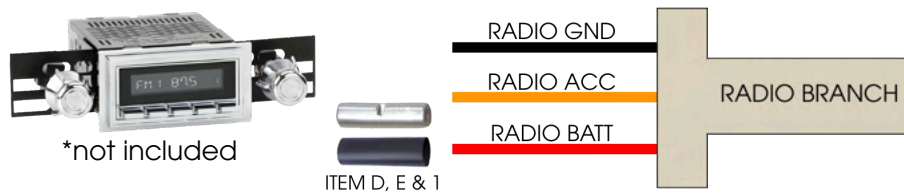

### TESTING Radio

- Radio on in ACC position

## Brake Switch Branch

The brake switch branch includes two conductors, 1) Brake Power, and 2) Brake. Brake Power is a fused 12V circuit with constant 12V. When the brake pedal is depressed, the switch activates and 12V passes to the Brake signal to the steering column and activates both rear brake lights.

CIRCUIT	CIRCUIT LABEL	I/O	WIRE COLOR	AWG	CIRCUIT CURRENT RATING	FUSE NAME	FUSE VALUE
Brake Power - Fused 12V Constant input to the switch	BRAKE PWR	I	RED	16	12A	BRAKE PWR	15A
Brake Output - Brake signal either 0 or 12V when pedal is pressed	BRAKE	O	LIGHT BLUE	16	12A	BRAKE PWR	15A

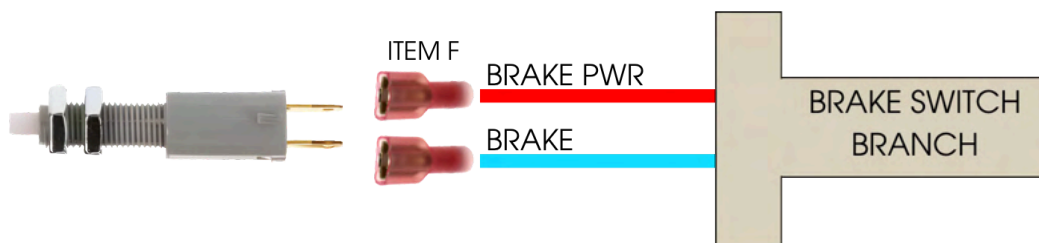

## E-Brake Switch Branch

FFG uses an electronic brake controller made by E-STOPP providing a complete electronic parking brake solution at the touch of a button.

The benefits of using an electric brake controller are all mechanical mechanisms are hidden outside the cab. Turning on and off the parking brake is easily controlled with a simple switch on the dash. This provides a very clean look to and eliminates interior foot pedal mechanisms.

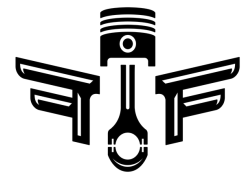

## E-Brake Switch Branch

CIRCUIT	CIRCUIT LABEL	I/O	WIRE COLOR	AWG	CIRCUIT CURRENT RATING	FUSE NAME	FUSE VALUE
E-Brake Indicator - this is a negative trigger output that can connect to a light or LED	EBRK IND	O	RED	18	12A	PWR LOCKS	20A
E-Brake Signal D - this runs between the ebrake controller and ebrake actuator through the rear sub harness	EBRK D	O	BLACK	16	12A	PWR LOCKS	20A
E-Brake Signal C - this runs between the ebrake controller and ebrake actuator through the rear sub harness	EBRK C	O	RED	16	12A	PWR LOCKS	20A
E-Brake +12V	EBRK 12V	I	RED	16	12A	PWR LOCKS	20A
Brake IGM - Ignition Interlock	EBRK IGM	I	PINK	16	12A	IGN/EFI/ECU	25A
Brake Ground - Dedicated ground for the controller	EBRK GND	GND	BLACK	16	12A	N/A	N/A

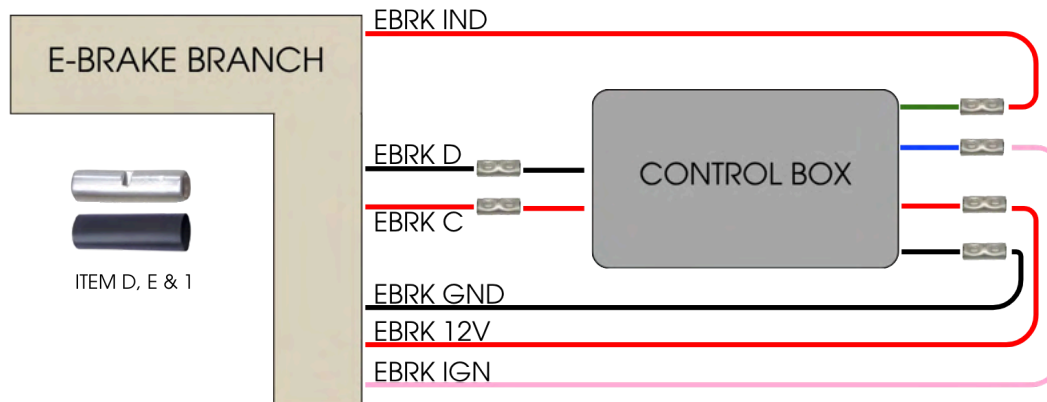

### TESTING Electronic E-Brake

- E-Brake functions

## Steering Column Branch

The steering column branch implements connections compatible with standard GM 4 ½ in. male connectors. Many aftermarket manufacturers use this connector including Flaming River used by FFG for classic 1967-72 builds. The GM 4 ½ male connector uses 8 connections for brake, turn, hazard light and horn functions. The harness uses the hazard functions integrated by aftermarket steering columns in place of stand-alone hazards switches in the dash. This allows using dash space for modern conveniences like power points, push-to-start and others maintaining a clean dash appearance.

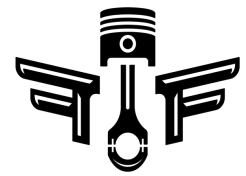

## Steering Column Branch

CIRCUIT	CIRCUIT LABEL	I/O	WIRE COLOR	AWG	CIRCUIT CURRENT RATING	FUSE NAME	FUSE VALUE
Horn Switch - fused 12V circuit providing 12V to horn when the steering wheel horn ring is pressed	HORN SW	0	YELLOW	18	8A	BRK/FLASHER	15A
Left Front Turn (x2) - two separate wires, one carrying fused 12V signals to front and rear harnesses when the blinker lever is turned to left indicator. The other wire is for the indicator light on the dash display.	LF TURN	0	LIGHT BLUE	16	12A	BRK/FLASHER	15A
Right Front Turn (x2) - two separate wires, one carrying fused 12V signals to front and rear harnesses when the blinker lever is turned to right indicator. The other wire is for the indicator light on the dash display.	RF TURN	0	RED	16	12A	BRK/FLASHER	15A
Hazard 12V Source - Fused 12V source which turns on hazard lights (front and rear turn signal lights) when the column switch is activated	HAZ PWR	I	RED	16	12A	BRK/FLASHER	15A
Turn 12V Source - Fused 12V source which turns on the left or right blinker lights when activated by the blinker lever on the steering column. (Brake light doubles as the blinker.)	TURN PWR	I	LIGHT BLUE	16	12A	BRK/FLASHER	15A
Left Rear Turn - Wire carries fused 12V signal to the rear left blinker when the lever is turn to the left (Brake light doubles as the blinker.)	LR TURN	0	YELLOW	16	16	BRK/FLASHER	15A
Right Rear Turn - Wire carries fused 12V signal to the rear right blinker when the lever is turn to the right (Brake light doubles as the blinker.)	RR TURN	0	DARK GREEN	16	16	BRK/FLASHER	15A
Brake - Provides a fused 12V signal to each the steering column turn switch.	BRAKE	I	LIGHT GREEN	16	16	N/A	N/A
Brake - Comes from an optional push-to-start module which allows the brake lights to be pulsed during lock or unlock function. This wire is fused at the push-to-start relay module.*	BRAKE	I	LIGHT GREEN	16	16	N/A	N/A

\*The two brake signals are connected to the same pin on the Steer Column connector.

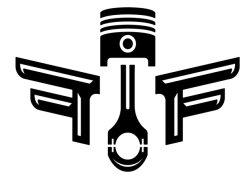

## Steering Column Branch

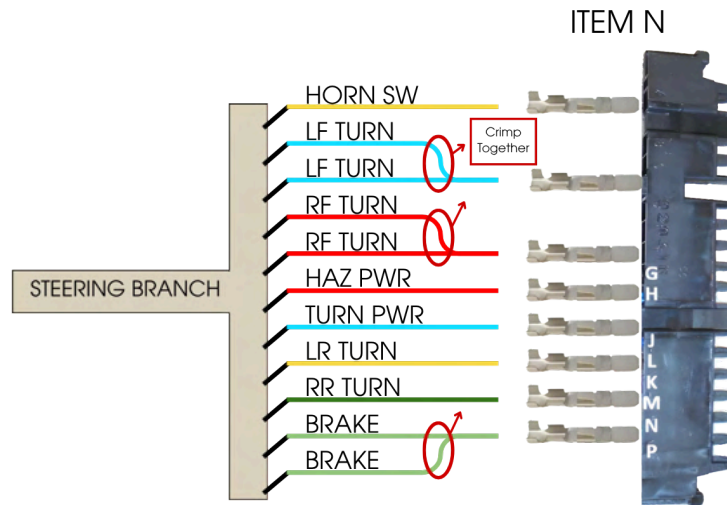

### TESTING Steering Column

- Horn                       Right turn front     Right turn rear     Brake lights  
 HAZARD                       Left turn front     Left turn rear

## Ground Bar Branch

Grounding in any automotive application is extremely important. A proper ground strategy helps guarantee a noise and anomaly free system operation.

**FFG RECOMMENDATION:** FFG uses a ground bar underneath the dash. All grounds under the dash are connected to this ground bar, thus all under-dash grounds are electrically connected to a central grounding point. The cab harness has 12 separate grounds for components mounted under the dash. The harness design along with good design practices requires the installer tie these grounds at one central point, thus a ground bar.

CIRCUIT	CIRCUIT LABEL	WIRE COLOR	AWG	CIRCUIT CURRENT RATING	FUSE NAME	FUSE VALUE
E-Brake Controller Ground Signal - Provides ground signal to the EStopp electronic parking brake controller.	EBRKE GND	BLACK	16	12A	N/A	N/A
Exhaust Cutout Ground Signal - Provides ground signal for optional exhaust cutout valves.	EX CUT GND	BLACK	16	12A	N/A	N/A
Power Point Ground Signal - Provides a dedicated ground signal the power port on the dash.	PWPOINT GND	BLACK	16	12A	N/A	N/A
Radio Ground Signal - Provides a dedicated ground signal to the radio.	RADIO GND	BLACK	16	12A	N/A	N/A
Auxiliary Ground 1 - Provides a dedicated ground to the front harness for auxiliary lighting or other purposes.	AUX GND1	BLACK	16	12A	N/A	N/A

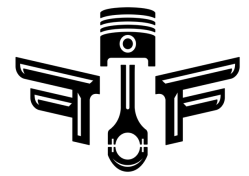

## Ground Bar Branch

CIRCUIT	CIRCUIT LABEL	WIRE COLOR	AWG	CIRCUIT CURRENT RATING	FUSE NAME	FUSE VALUE
Auxiliary Ground 2 - Provides a dedicated ground to the rear harness for the auxiliary lighting or other purposes.	AUX GND2	BLACK	16	12A	N/A	N/A
HVAC Ground - Provides a dedicated ground to the air conditioning module controller under the dash.	HVAC GND	BLACK	16	12A	N/A	N/A
Ground 1 - Provides a ground signal for all electronic modules in the DDS branch to use as their power ground.	GND1	BLACK	16	12A	N/A	N/A
Ground 2 - Provides a ground signal for all electronic modules in the DDS branch to use as their power ground.	GND2	BLACK	16	20A	N/A	N/A
Ground for left door split	LF DOOR GND	BLACK	16	20A	N/A	N/A
Ground for right door split	RT DOOR GND	BLACK	16	20A	N/A	N/A
Transmission fluid fan ground	TRANS GND	BLACK	16	20A	N/A	N/A

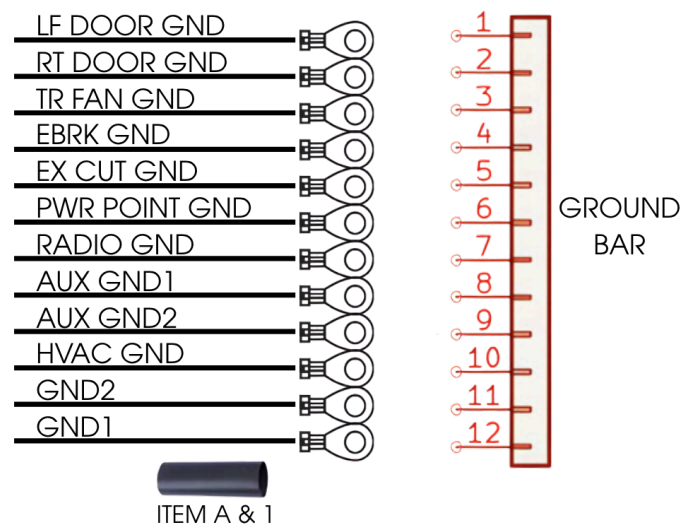

## Coach Driver Branch

To protect your classic truck investment a fuse control panel is required. At FFG we use the Coach Controls, Coupe-23 power center. While this harness kit is built to connect to the Coach Control fuse block, it can easily be adapted to other fuse blocks. This is done by re-purposing the Coach Driver and Passenger wire harness branches for your own specific purposes.

**FFG RECOMMENDATION:** Should the installer choose to use a different fuse control block, please pay close attention to the pinout description and circuit specification details listed below to ensure a trouble-free installation.

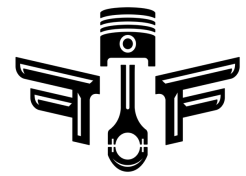

# Coach Driver Branch

CIRCUIT	CIRCUIT LABEL	I/O	WIRE COLOR	AWG	CURRENT RATING	RING TERMINAL	END POINT	FUSE NAME	FUSE VALUE
Brake light 12V	BRAKE PWR	0	RED	16	15A	E18	Headlight SW	BRK/FLASHER	15A
Hazard light 12V	HAZ PWR	0	RED	16	15A	E19	Headlight SW	BRK/FLASHER	15A
Turn light 12V	TURN PWR	0	RED	16	15A	E20	Headlight SW	BRK/FLASHER	15A
Push-to-Start accessory switch	PTS ACC SW	I	RED	16	15A	J3-1	PTS Branch - Relay Module	Relay switch input	N/A
Accessory Switch	ACC SW	I	ORANGE	18	6A	J3-1	Ignition SW	Relay switch input	N/A
Push-to-Start ignition switch	PTS IGN SW	I	RED	18	6A	J3-2	PTS Branch - Relay Module	Relay switch input	N/A
Ignition switch	IGN SW	I	PINK	18	6A	J3-2	Ignition SW	Relay switch input	N/A
Horn switch	HORN SW	I	YELLOW	18	6A	J3-4	PTS Branch - Relay Module	Steering Column Branch	N/A
Horn push-to-start switch	HORN PTS	I	LIGHT GREEN	18	6A	J3-4	PTS Branch - Relay Module	Relay switch input	N/A
Low beam switch	LOW	I	TAN	18	6A	J3-5	Dimmer Branch	Relay switch input	N/A
Push-to-Start light switch	LIGHT PTS 1	I	GRAY	18	6A	J3-5	PTS Branch - Relay Module	Relay switch input	N/A
High beam switch	HIGH	I	LIGHT GREEN	18	6A	J3-6	Dimmer Branch	Relay switch input	N/A
HVAC switch	HVAC SW	I	ORANGE	18	6A	J3-7	PTS Branch - Restomod	Relay switch input	N/A
GND	N/A	P	BLACK	16	6A	J3-8	N/A	N/A	N/A
HVAC controller battery connection	HVAC BAT	0	RED	16	15A	E5	PTS Branch - Restomod	Relay switch input	N/A
Dome light 12V	DOME	0	WHITE	16	15A	E21	Dome Branch	CLOCK/DOME	10A
Radio 12V	RADIO BATT	0	RED	16	15A	E21	Radio Branch	CLOCK/DOME	10A
Speed Module 12V	SPD 12V BAT	0	RED	16	15A	E22	Front - Bulkhead	IGN SW	10A
Dakota Digital 12V	DD 12V BAT	0	RED	16	15A	E22	DD Branch - Speed	IGN SW	10A
Ignition 12V	IGN 12V BAT	0	RED	16	15A	E22	Ignition SW Branch	IGN SW	10A
Push-to-Start module 12V	HD 12V BAT	0	RED	16	15A	E23	PTS Branch - Relay Module	HD LT SW	15A
Headlights 12V	HD 12V BAT	0	RED	16	15A	E23	Headlight SW Branch	HD LT SW	15A
Horn 12V	HORN	0	DARK GREEN	16	15A	E24	Front Bulkhead	HORN	20A
Door Lock Actuator 12V	DOOR LK PWR	0	ORANGE	16	15A	E26	LF Door Branch	PWR LOCKS	25A

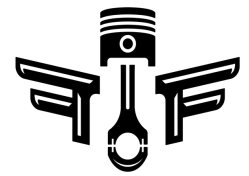

## Coach Driver Branch

CIRCUIT	CIRCUIT LABEL	I/O	WIRE COLOR	AWG	CURRENT RATING	RING TERMINAL	END POINT	FUSE NAME	FUSE VALUE
Door Lock Actuator 12V	DOOR LK PWR	0	ORANGE	16	15A	E26	RT Door Branch	PWR LOCKS	25A
Emergency Brake 12V	RADIO BATT	0	RED	16	15A	E26	EBRKE Branch	PWR LOCKS	10A

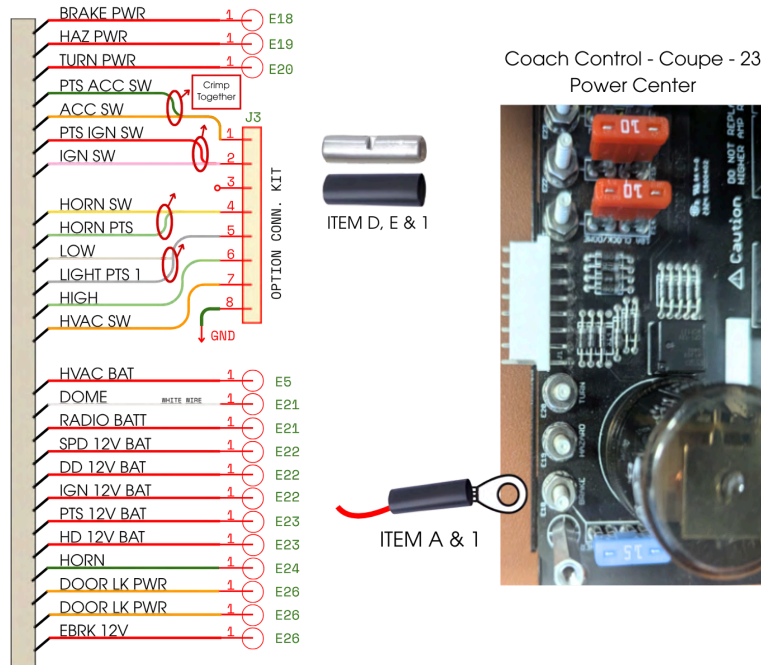

## Coach Passenger Branch

The Coach “driver” and “passenger” branches of the harness refer to two different splits in the harness which groups signals on the left and right side for easier routing.

CIRCUIT	CIRCUIT LABEL	I/O	WIRE COLOR	AWG	CIRCUIT CURRENT RATING	RING TERMINAL	END POINT	FUSE NAME	FUSE VALUE
HVAC 12V source	HVAC IGN	0	PINK	16	15A	E1	PTS Branch - Restomod	Fuel Pump	25A
Super Charger 12V source	SC IGN	0	PINK	16	15A	E2	Front Bulkhead	IGN/EFI/ECU	25A
EBrake 12V source	EBRK IGN	0	PINK	16	15A	E2	EBRK Branch	IGN/EFI/ECU	25A
Control Pack 12V source	CTL PK IGN	0	PINK	16	15A	E2	Front Bulkhead	IGN/EFI/ECU	25A
Gear Module 12V source	GEAR IGN	0	PINK	16	15A	E3	PTS Branch - Gear	IGN ACCYS	20A

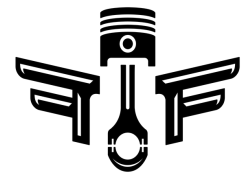

# Coach Passenger Branch

CIRCUIT	CIRCUIT LABEL	I/O	WIRE COLOR	AWG	CIRCUIT CURRENT RATING	RING TERMINAL	END POINT	FUSE NAME	FUSE VALUE
Dakota Digital RTX 12V source	DD IGN	0	PINK	16	15A	E3	DD Branch - DD RTX	IGN ACCYS	20A
Speed Module 12V source	SPD IGN	0	PINK	16	15A	E3	DD Branch - Speed	IGN ACCYS	20A
AC Clutch 12V source	AC CLUTCH	0	YELLOW	16	15A	E4	Front Bulkhead	N/A	N/A
Right Door Panel 12V	RT DR PNL	0	VIOLET	16	15A	E5	RT Door Branch	HEAT/AC	30A
Left Door Panel 12V	LF DR PNL	0	VIOLET	16	15A	E5	LF Door Branch	HEAT/AC	30A
Exhaust Cutouts 12V source	EX CUT	0	PINK	16	15A	E6	Rear Bulkhead	PWR POINT	10A
Power Point 12V source	PWR POINT	0	PINK	16	15A	E6	Power Point Branch	PWR POINT	10A
Transmission cooler fan	TR FAN	0	YELLOW	16	15A	E6	Power Point Branch	PWR POINT	10A
Left Front HD low beam 12V source	LF HD LB	0	TAN	16	15A	E7	Front Bulkhead	LOW BEAMS	20A
Right Front HD low beam 12V source	RF HD LB	0	TAN	16	15A	E7	Front Bulkhead	LOW BEAMS	20A
Left Front HD high beam 12V source	LF HD HB	0	LIGHT GREEN	16	15A	E8	Front Bulkhead	HIGH BEAMS	30A
Right Front HD high beam 12V source	RF HD HB	0	LIGHT GREEN	16	15A	E8	Front Bulkhead	HIGH BEAMS	30A
High Beam Indicator	HB IND	0	BROWN	16	6A	E8	DD Branch - DD RTX	HIGH BEAMS	30A
Left Power Window 12V source	LF WIN PWR	0	DARK BLUE	16	15A	E9	LF Door Branch	PWR WINDOW	30A
Right Power Window 12V source	RT WIN PWR	0	DARK BLUE	16	15A	E9	RT Door Branch	PWR WINDOW	30A
Wiper Switch 12V source	WIPER IGN	0	PINK	16	15A	E10	Wiper Branch	WIPERS	20A
Radio 12V accessory source	RADIO ACC	0	ORANGE	16	15A	E11	Radio Branch	RADIO/AMP	20A
Auxiliary 12V source dash pigtail	AUX ACC	0	ORANGE	16	15A	E11	Auxiliary Branch	RADIO/AMP	20A
Daytime Running Lights 12V source	DRL	0	WHITE	16	15A	E11	Front Bulkhead	RADIO/AMP	20A

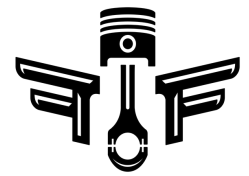

# Coach Passenger Branch

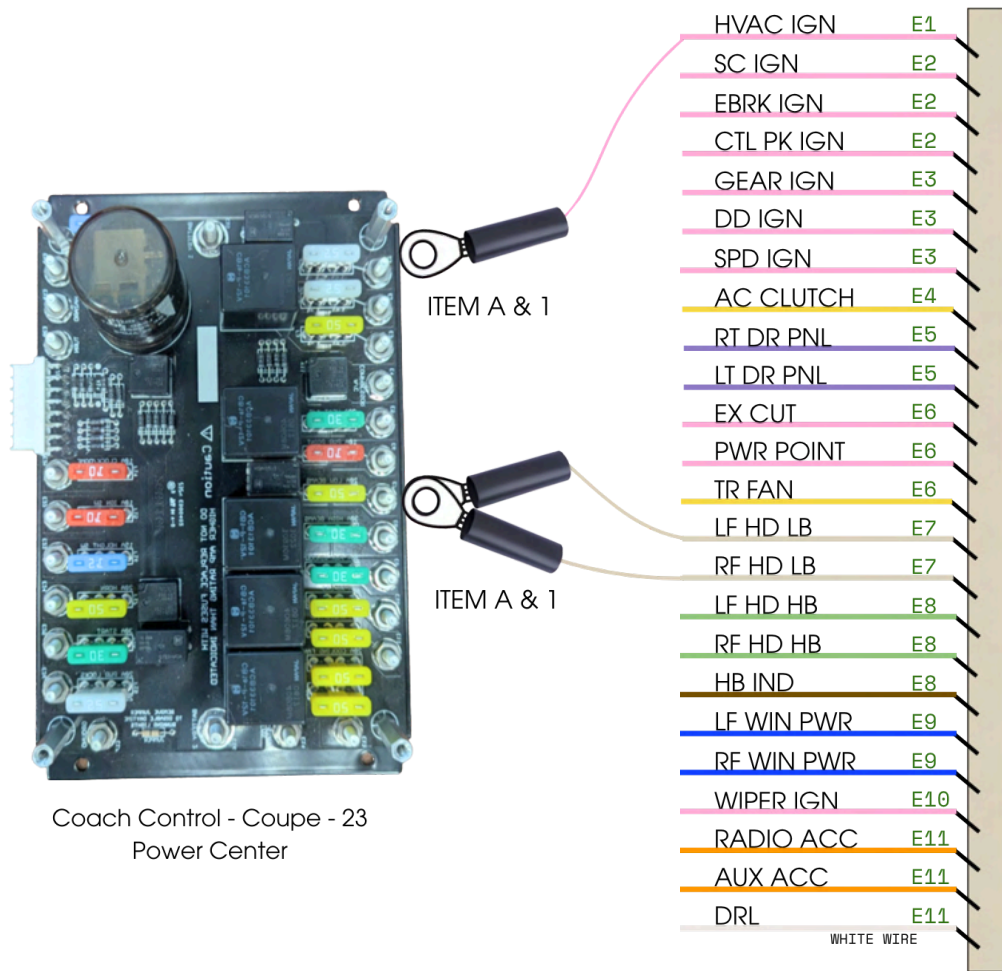

Coach Control - Coupe - 23  
Power Center



# DD Branch - Dakota Digital RTX

The harness branch supports connections to digital dash, tachometer, speed and BMI modules. FFG uses the Dakota Digital's RTX, HDX, VHX series controller and the GS-3000 universal gear shift sender; used for gear notification and possible interlocks. A universal Autometer tachometer interface is also used with the harness branch.

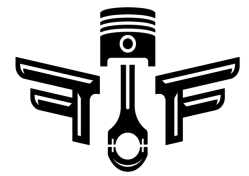

# DD Branch - Dakota Digital RTX

CIRCUIT	CIRCUIT LABEL	I/O	WIRE COLOR	AWG	CIRCUIT CURRENT RATING	END POINT	FUSE NAME	FUSE VALUE
Fuel level sender ground	FUEL LVL GND	P	BLACK	18	8A	Rear Bulkhead	N/A	N/A
Fuel level sender signal	FUEL LVL	I	GRAY	18	8A	Rear Bulkhead	N/A	N/A
Oil pressure sender power	OP PWR	P	RED	18	8A	Front Bulkhead	N/A	N/A
Oil pressure sender ground	OP GND	P	BLACK	18	8A	Front Bulkhead	N/A	N/A
Oil pressure sender signal	OP SIG	I	WHITE	18	8A	Front Bulkhead	N/A	N/A
Cylinder temperature sender ground	C TEMP GND	P	BLACK	18	8A	Front Bulkhead	N/A	N/A
Cylinder temperature sender signal	C TEMP	I	YELLOW	18	8A	Front Bulkhead	N/A	N/A
1-Wire speed signal	SPD SIG	I	YELLOW	18	8A	GS-3000 Speed	N/A	N/A
Tach Signal	TACH	I	ORANGE	18	8A	Cab Harness PTS split, tach adapter	N/A	N/A
Tach signal	TACH	O	ORANGE	18	8A	Cab Harness DD split, PTS module	N/A	N/A
Dakota Digital ignition power	DD IGN	P	PINK	18	8A	Coach Control	IGN ACCYS	20A
Dakota Digital 12V power source	DD 12V BAT	P	RED	16	15A	Coach Control	Headlight SW	15A
High beam indicator	HIGH	I	LIGHT GREEN	16	15A	Dimmer Switch	N/A	N/A
CEL (Check Engine Light) indicator	CEL	I	BLACK	18	8A	Front Harness	N/A	N/A
E-Brake indicator signal	EBRK IND	I	RED	18	8A	Rear Harness	N/A	N/A
Headlight high beam indicator	HB IND	I	BROWN	16	15A	Coach Control	High Beams	30A
Left turn indicator	LF TURN	I	LIGHT BLUE	18	8A	Steering Column Split	N/A	N/A
Right turn indicator	RF TURN	I	DARK BLUE	18	8A	Steering Column Split	N/A	N/A
1-Wire gear indicator	GEAR	I	BROWN	18	8A	PTS Split - Gear Module	N/A	N/A
Dome Light on indicator	DOME SW	I	BLACK	16	15A	Headlight Split	N/A	N/A
Shared ground connection	GND1	P	BLACK	16	15A	Ground Block Split	N/A	N/A



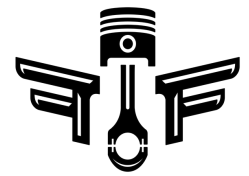

## DD Branch - Tach Adapter

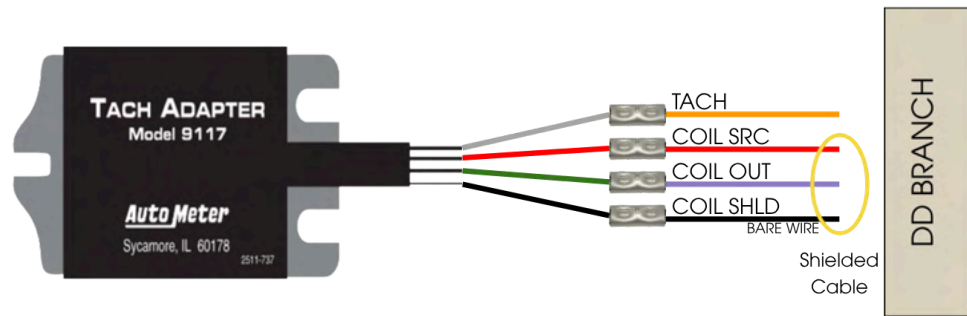

## DD Branch - Dakota Digital GPS-50-2 Speed Module

The cab harness couples with the Dakota Digital GPS-50-2 speed module. The module uses GPS to determine vehicle speed. A 1-wire interface transmits speed information from the Dakota Digital speed module to the Dakota Digital RTX gauge controller.

CIRCUIT	CIRCUIT LABEL	I/O	WIRE COLOR	AWG	CIRCUIT CURRENT RATING	END POINT	FUSE NAME	FUSE VALUE
Speed Module Battery - Input	SPD IGN	I	PINK	18	8A	Coach Driver Branch	IGN ACCYS	20A
Speed Module Ignition - Input	SPD 12V BAT	I	RED	16	15A	Coach Passenger Branch	IGN SW	15A
1-Wire speed signal - Output	SPD SIG	O	YELLOW	18	8A	DD Branch - DD RTX	N/A	N/A

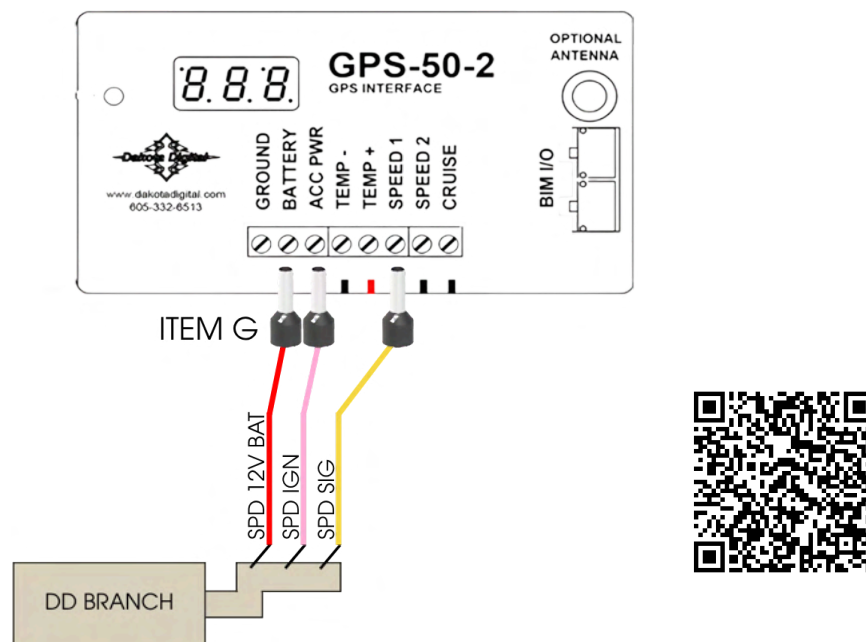



## PTS Branch - Push to Start Relay Module

This section of the harness is dedicated to connections for optional an push-to-start relay module. Currently, FFG uses push-to-start modules by Vais. Included in their PTS kit is a relay module which controls engine start and if desired; horn, lights, and power door lock/unlock triggers for proximity lock and unlock functions.

**IMPORTANT NOTE:** The FFG harness supports, a) standard ignition **OR** b) push-to-start feature. The installer should ensure the harness connections for either the standard ignition switch or PTS, whichever is NOT used, are properly terminated using heat shrink on wire ends and tied out of the way.

CIRCUIT	CIRCUIT LABEL	I/O	WIRE COLOR	AWG	CIRCUIT CURRENT RATING	END POINT	FUSE NAME	FUSE VALUE
PTS constant 12V battery	PTS 12V BAT	I	RED	16	20A	Coach Control	N/A	N/A
PTS switched ignition, used as a switched input to the Coach fuse panel	PTS IGN SW	O	RED	16	15A	Coach Control	N/A	N/A
PTS switched accessory used as a switched input to the Coach fuse panel	PTS ACC SW	O	DARK GREEN	18	8A	Coach Control	N/A	N/A
Brake applied safety signal	BRAKE	I	LIGHT BLUE	18	8A	Steering Split	N/A	N/A
Tachometer safety signal	TACH	I	ORANGE	18	8A	DD Split	N/A	N/A
PTS starter signal	PTS ST SW	O	YELLOW	18	8A	Clutch Split	N/A	N/A
PTS Light 1 to flash lights etc, used as a switched input to the Coach fuse panel	LIGHT PTS 1	O	GRAY	18	8A	Coach Split	N/A	N/A
PTS Light 2 to flash front and rear parking lights	LIGHT PTS 2	O	BROWN	18	8A	HD LT SW Split	N/A	N/A
PTS lock trigger - (x2, one for each left and right sides, tied together)*	LOCK	O	DARK GREEN DARK GREEN	16	15A	LF Door Split & RT Door Split	N/A	N/A
PTS unlock trigger - (x2, one for each left and right sides, tied together)**	UNLOCK	O	DARK BLUE DARK BLUE	16	15A	LF Door Split & RT Door Split	N/A	N/A
PT horn used to activate the horn or a siren, used as a switched input to the Coach fuse panel	HORN PTS	O	LIGHT GREEN	18	8A	Coach Control	IGN ACCY	20A
Shared ground connection	GND2	P	BLACK	16	15A	Ground Block Split	N/A	N/A

\*Both LOCK signals are tied together and connected to the PTS module.

\*\*Both UNLOCK signals are tied together and connected to the PTS module.



## PTS Branch - Push to Start Relay Module

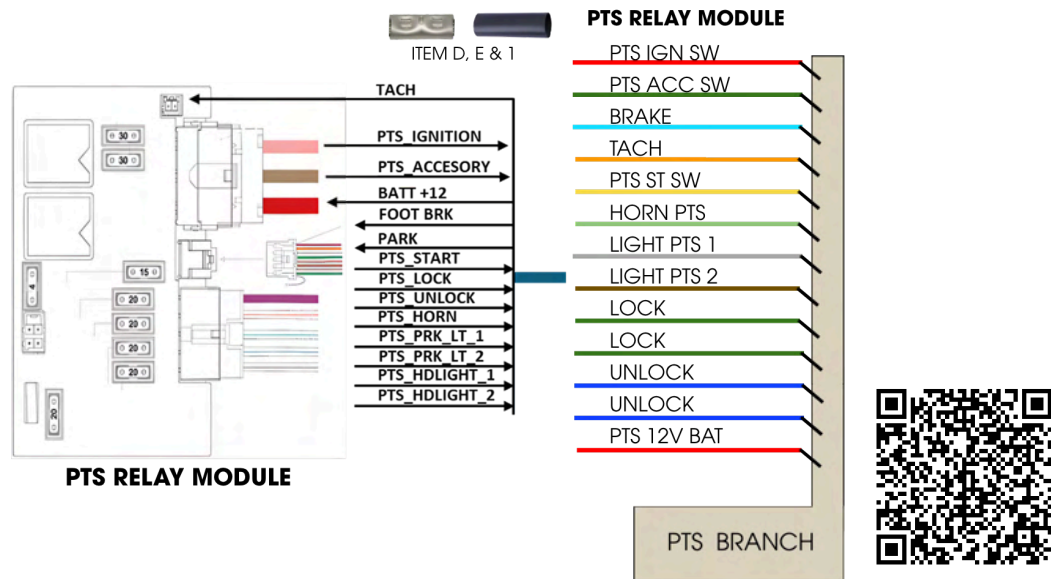

## PTS Branch - Gear Module

This harness branch is for the gear detection module. FFG uses the Dakota Digital GSS-3000. For this module the 1-wire connection is used to transmit gear position information to the Dakota Digital RTX gauge controller. Also, backup lights are driven directly from the GSS-3000 through the harness to the rear backup lights. Three circuit wires are dedicated to the selection solenoid which is installed near the transmission gear linkage.

CIRCUIT	CIRCUIT LABEL	I/O	WIRE COLOR	AWG	CURRENT RATING	END POINT	FUSE NAME	FUSE VALUE
Gear IGN 12V	GEAR IGN	I	PINK	16	15A	Coach Passenger Branch	N/A	N/A
Backup Signal	BACKUP	O	WHITE	16	15A	Rear Bulkhead	N/A	N/A
Gear selection signal	GEAR	O	BROWN	18	8A	DD Branch - Dakota RTX	N/A	N/A
Gear sensor signal	GEAR RED	I	RED	18	8A	Rear Bulkhead	N/A	N/A
Gear sensor signal	GEAR GRN	I	DARK GREEN	18	8A	Rear Bulkhead	N/A	N/A
Gear sensor signal	GEAR BLK	I	BLACK	18	8A	Rear Bulkhead	N/A	N/A

**IMPORTANT NOTE:** For Manual Transmissions (MT), GEAR IGN shall be connected to GEAR RED. GEAR RED in the Rear Harness will attach to the Backup switch on the MT. In the Rear Harness the other side of the MT Backup switch will connect to the backup lights.

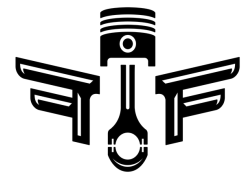

## PTS Branch - Gear Module

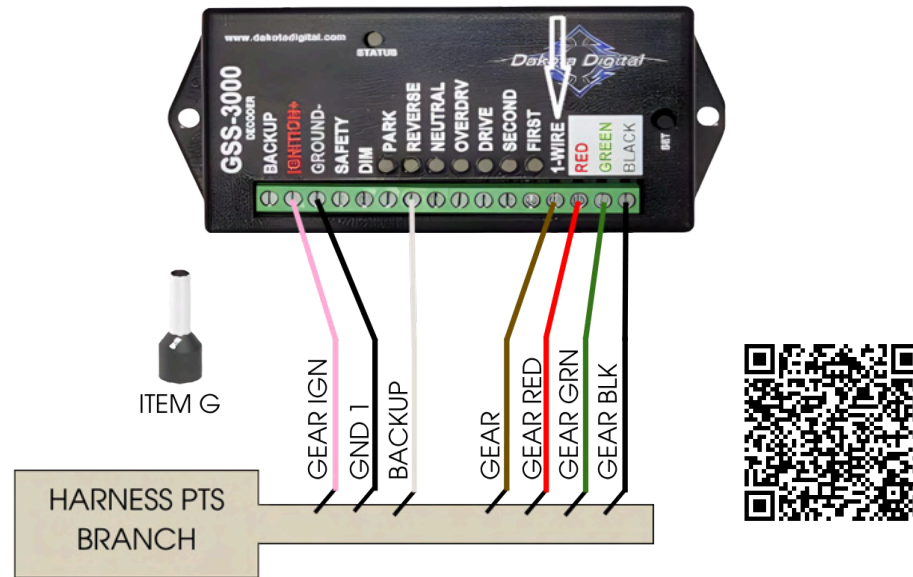

## PTS Branch - RestoMod Module

This harness branch connects directly to a RestoMod or Vintage Air HVAC controller. The circuits included are for powering the RestoMod or Vintage Air controller and the signals needed to turn on the AC Clutch.

CIRCUIT	CIRCUIT LABEL	I/O	WIRE COLOR	AWG	CIRCUIT CURRENT RATING	END POINT	FUSE NAME	FUSE VALUE
HVAC 12V Bat	HVAC BAT	I	RED	16	15A	Coach Passenger Branch	N/A	N/A
HVAC 12V IGN	HVAC IGN	I	PINK	16	15A	Coach Passenger Branch	N/A	N/A
HVAC gnd	HVAC GND	I	BLACK	16	15A	Ground Bar Branch	N/A	N/A
HVAC Compressor signal	HVAC SW	O	WHITE	18	8A	Coach Driver Branch	N/A	N/A





## PTS Branch - RestoMod Module

### TESTING Dash Gauges

- Speedometer
- Turn indicators
- Engine light (CEL)
- Gear indicator
- High beam indicator
- E-Brake indicator
- Tachometer
- Engine temperature
- Oil pressure
- Fuel level

### HVAC

- HVAC bat power
- HVAC IGN power
- HVAC SW to turn on AC Clutch
- Push-To-Start (If equipped - Cab PTS SPLIT)
- Power windows (If equipped)
- Power door locks (If equipped)

## Front Bulkhead Branch - Pinout

PIN	CIRCUIT	LABEL	I/O	WIRE COLOR	AWG	CIRCUIT CURRENT RATING	FUSE NAME	FUSE VALUE
1	Right Front Headlight High Beam	RF HD HB	0	LIGHT GREEN	16	12A	HIGH BEAM	30A
2	Right Front Headlight Low Beam	RF HD LB	0	TAN	16	12A	LOW BEAM	20A
3	Right Front Turn Signal	RF TURN	0	DARK BLUE	16	12A	FLASHER	15A
4	Front Parking/Marker Lights	MARKER	0	BROWN	16	12A	HDLGHT SW	15A
5	Auxiliary Lighting	AUX	0	ORANGE	16	12A	RADIO/AMP	20A
6	Auxiliary Lighting Ground	AUX GND1	0	BLACK	16	12A	N/A	N/A
7	Horn	HORN	0	DARK GREEN	16	12A	HORN	20A
8	Left Front High Beam	LF HD HB	0	LIGHT GREEN	16	12A	HIGH BEAM	20A
9	Left Front Low Beam	LF HD LB	0	TAN	16	12A	LOW BEAM	20A
10	Daytime Running Light	DRL	0	WHITE	16	12A	RADIO/AMP	20A
11	Left Front Turn Signal	LF TURN	0	LIGHT BLUE	16	12A	FLASHER	15A
12	NC							
13	Check Engine Indicator	CEL	I	BLACK	18	8A	N/A	N/A
14	Windshield Wiper Pump	WSHR PMP	0	LIGHT GREEN	16	15A	WIPERS	20A
15	Air Conditioning Clutch	AC CLUTCH	0	YELLOW	16	15A	N/A	N/A
16	Engine Control Pack Ignition Signal	CTL PK IGN	0	PINK	16	12A	IGN/EFI/ECU	30A
17	Engine Start Signal	START REQ	0	VIOLET	16	12A	IGN SW	10A
18	Oil Pressure Sensor Power	OP PWR	0	RED	18	8A	IGN SW	10A
19	Oil Pressure Sensor Ground	OP GND	I	BLACK	18	8A	N/A	N/A
20	Oil Pressure Sensor Signal	OP SIG	I	WHTIE	18	8A	N/A	N/A



## Front Bulkhead - Pinout

PIN	CIRCUIT	LABEL	I/O	WIRE COLOR	AWG	CIRCUIT CURRENT RATING	FUSE NAME	FUSE VALUE
21	Tach, Coil Supply Voltage Input	COIL SRC	I	RED	20	5A	N/A	N/A
22	Tach, Coil Supply Voltage Output to Coils	COIL OUT	O	VIOLET	20	5A	N/A	N/A
23	Tach, Cable Drain Wire for Shielding	COIL SHLD	I	BARE	20	5A	N/A	N/A
24	Cylinder Head Temperature Sensor Signal	C TEMP	I	YELLOW	18	8A	N/A	N/A
25	Cylinder Head Temperature Sensor Ground	C TEMP GND	O	BLACK	18	8A	N/A	N/A
26	NC							
27	NC							
28	Fuel Pressure Sensor Ground	FL PR BLK	O	BLACK	18	8A	N/A	N/A
29	Fuel Pressure Sensor Power	FL PR GRAY	O	GRAY	18	8A	VAPOR WORKS	VARIES
30	Fuel Pressure Sensor Signal	FL PR BRN	I	BROWN	18	8A	VAPOR WORKS	VARIES
31	Supercharger Cooler	SC IGN	O	PINK	16	12A	IGN/EFI/ECU	25A

## Rear Bulkhead - Pinout

PIN	CIRCUIT	LABEL	I/O	WIRE COLOR	AWG	CURRENT RATING	FUSE NAME	FUSE VALUE
A	Tail Light	TAIL	O	BROWN	16	15A	HDLIGHT SW	15A
B	Tail Light	TAIL	O	BROWN	16	15A	HDLIGHT SW	15A
C	Backup Light	BACKUP	O	WHITE	16	15A	IGN ACCYS	10A
D	Left Rear Turn Signal	LR TURN	O	YELLOW	16	15A	FLASHER	15A
E	Right Rear Turn Signal	RR TURN	O	DARK GREEN	16	15A	FLASHER	15A
F	Rear Parking or Marker lights	PARK	O	BROWN	16	15A	HDLGHT SW	15A
G	Fuel Pressure Sensor Signal	FL PR BRN	I	BROWN	16	15A	VAPOR WORKS	25A
H	Fuel Pressure Sensor Power	FL PR GRAY	O	GRAY	18	8A	VAPOR WORKS	25A
J	Fuel Pressure Sensor Ground	FL PR BLK	O	BLACK	18	8A	N/A	N/A
K	Auxiliary Lighting	AUX	O	ORANGE	16	15A	RADIO/AMP	20A
L	Rear Auxiliary Lighting Ground	AUX GND2	O	BLACK	16	15A	N/A	N/A
M	Exhaust Cutout Signal 1	EX CUT 1	O	VIOLET	16	15A	POWER POINT	10A
N	Exhaust Cutout Signal 2	EX CUT 2	O	BROWN	16	15A	POWER POINT	10A
O	Electronic E-Brake Ground	EBRK D	O	BLACK	16	15A	N/A	N/A
P	Electronic E-Brake Power	EBRK C	O	RED	16	15A	IGN/EFI/ECU	25A

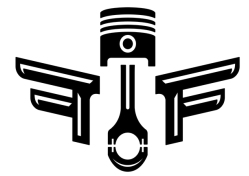

## Rear Bulkhead Branch - Pinout

PIN	CIRCUIT	LABEL	I/O	WIRE COLOR	AWG	CURRENT RATING	FUSE NAME	FUSE VALUE
Q	Transmission cooler fan	TR FAN	I	YELLOW	16	15A	POWER POINT	10A
R	Transmission cooler fan gnd	TRAN FAN GND	I	BLACK	16	15A	POWER POINT	10A
S	Fuel Level Sensor Signal	FUEL LVL	I	GRAY	18	8A	VAPOR WORKS	25A
T	Fuel Level Sensor Signal	FUEL LVL GND	O	BLACK	18	8A	N/A	N/A
U	Gear Selection Signal (Black)	GEAR BLACK	I	BLACK	18	8A	IGN ACCYS	10A
V	Gear Selection Signal (Green)	GEAR GRN	I	DARK GREEN	18	8A	IGN ACCYS	10A
W	Gear Selection Signal (Red)	GEAR RED	I	RED	16	15A	IGN ACCYS	10A
X	NC							

## REAR SUB-HARNESS

The rear sub-harness design uses a bulkhead connector by TE Connectivity with Deutsch contacts. With the turn of a ring at this connector, the rear harness is easily disconnected for serviceability.

The bulkhead connector has 23 contacts. The rear sub-harness comes with the connector, terminations/contacts and seals completely assembled. It is also equipped with eight pigtail splits allowing the builder to run wire groups as needed. The bulkhead connector is located on the passenger side firewall.

The main section of the wire harness runs from the bulkhead connector along the right chassis rail to the rear of chassis. From there the harness tees, the left branch going to the left tail light assembly and right to the right tail light assembly.

Rear Sub-Harness  
Bulkhead Connector

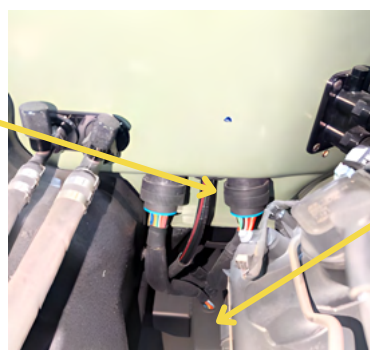

Right Frame  
Member

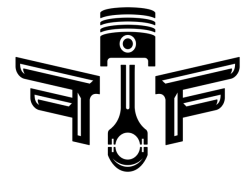

## Right Branch Connections

The right harness supports the right tail light, brake/turn light, backup light, and marker light. If you have purchased the connector kit you will need to add connectors as follows.

CIRCUIT	CIRCUIT LABEL	WIRE COLOR	AWG	CIRCUIT CURRENT RATING	FUSE NAME	FUSE VALUE
Marker/Parking light for right side	PARK*	BROWN	16	6A	HDLGHT SW	15A
Marker/Parking light, tied in for left light	PARK*	BROWN	16	6A	HDLGHT SW	15A
Backup light for right side	BACKUP**	WHITE	16	6A	IGN ACCYS	10A
Backup light, ties in for left light	BACKUP**	WHITE	16	6A	IGN ACCYS	10A
Right Rear Turn Signal	RT TURN	DARK GREEN	16	12A	FLASHER	15A
Right Rear Tail	RR TAIL	BROWN	16	12A	HDLGHT SW	15A
License Plate Light, this circuit ties into the RR TAIL circuit	LICENSE	WHITE	16	6A	HDLGHT SW	15A
Right Rear Tail Light Assembly Ground***	RR TAIL GND	BLACK	16	24A	N/A	N/A

\*The left and right PARK circuit share the same conductor from the bulkhead connector. Each PARK circuit is rated for 6A.

\*\*The left and right BACKUP share the same conductor from the bulkhead connector. Each BACKUP circuit is rated for 6A.

\*\*\*The RR TAIL GND is 16 AWG provides a local current path for all tail assembly lights. Please ensure a maximum of 20A for this 24 in. conductor.

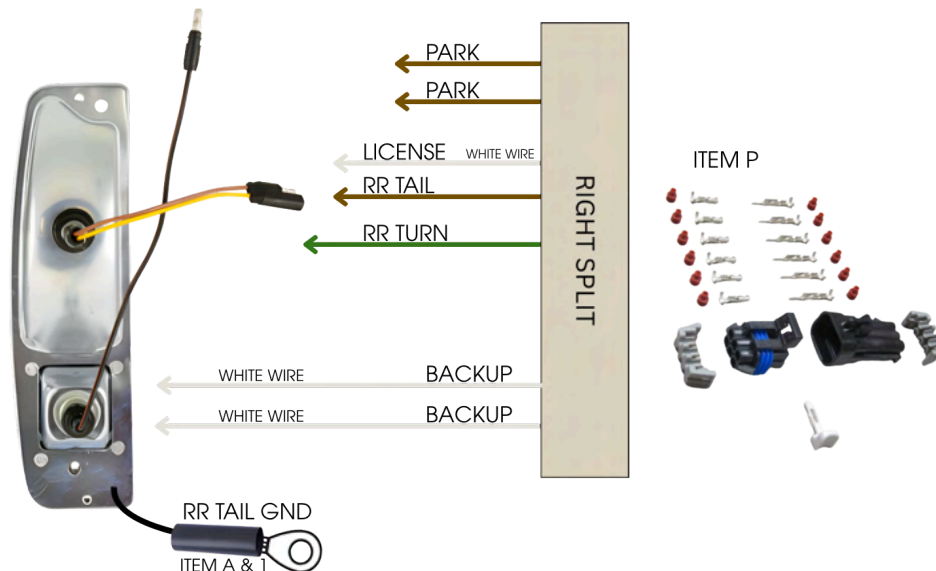

### TESTING Passenger Taillight Assembly

- Passenger taillight       Passenger backup light       License plate lights  
 Passenger parking light       Passenger turn signal

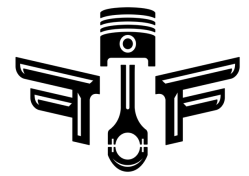

## Left Branch Connections

The left harness branch includes the left tail light, brake light, backup light, marker light and right turn signal.

CIRCUIT	CIRCUIT LABEL	WIRE COLOR	AWG	CIRCUIT CURRENT RATING	FUSE NAME	FUSE VALUE
Marker/Parking light for left side	PARK*	BROWN	16	6A	HDLGHT SW	15A
Backup light for left side	BACKUP**	WHITE	16	6A	IGN ACCYS	10A
Left Rear Turn Signal	LR TURN	DARK GREEN	16	12A	FLASHER	15A
Left Rear Tail	LR TAIL	BROWN	16	12A	HDLGHT SW	15A
Left Rear Tail Light Assembly Ground***	LR TAIL GND	BLACK	14	24A	N/A	N/A

\*The left and right PARK circuit share the same conductor from the bulkhead connector. Each PARK circuit is rated for 6A.

\*\*The left and right BACKUP share the same conductor from the bulkhead connector. Each BACKUP circuit is rated for 6A.

\*\*\*The LR TAIL GND is 16 AWG provides a local current path for all tail assembly lights. Please ensure a maximum of 20A for this 24 in. conductor.

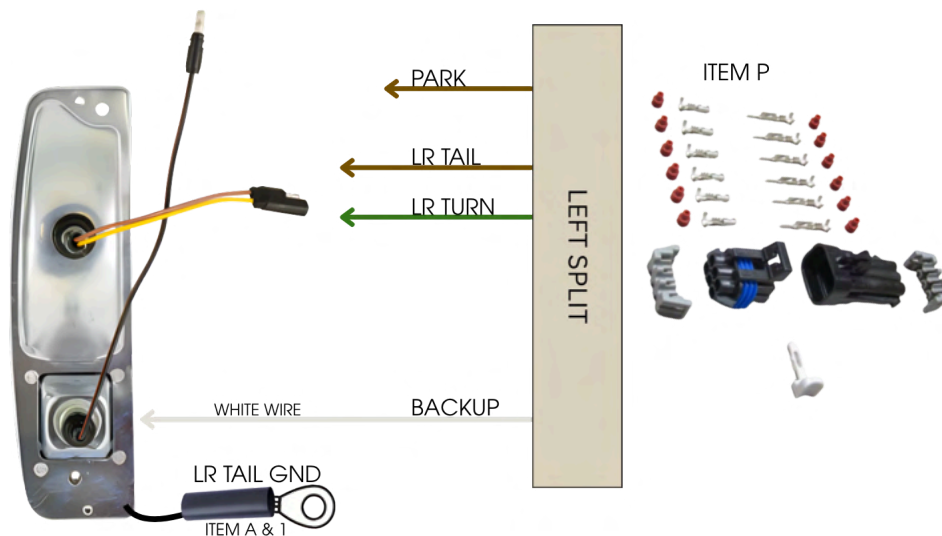

### TESTING Driver Taillight Assembly

- Driver taillight       Driver backup light  
 Driver parking light       Driver turn signal



## Fuel Branch

The Fuel branch has provisions for a fuel level sensor and a fuel pressure sensor.

CIRCUIT	CIRCUIT LABEL	WIRE COLOR	AWG	CIRCUIT CURRENT RATING	FUSE NAME	FUSE VALUE
Fuel Pressure Sensor Signal	FL PR BRN	BROWN	18	16A	Vapor Works	Varies
Fuel Pressure Sensor Power	FL PR GRAY	GRAY	18	16A	Vapor Works	Varies
Fuel Pressure Sensor Ground	FL PR BLK	BLACK	18	16A	Vapor Works	Varies
Fuel Level Sensor Signal	FUEL LVL	GRAY	18	8A	Vapor Works	Varies
Fuel Level Sensor Ground	FUEL LVL GND	BLACK	18	8A	N/A	N/A

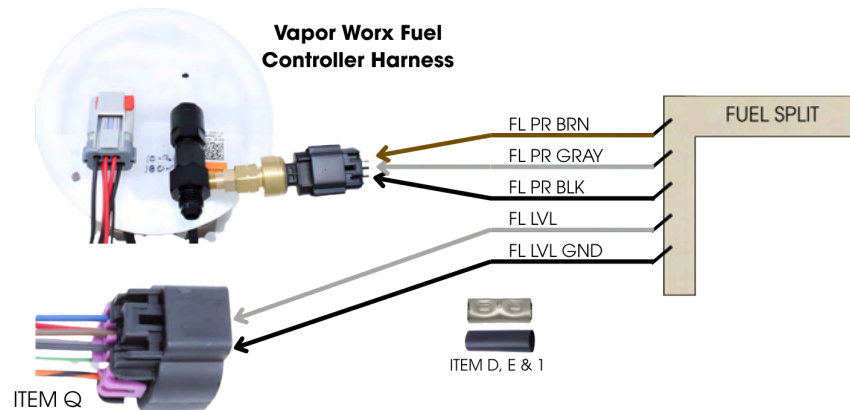

### TESTING Fuel Branch

- Map signal     
  Fuel pressure signal     
  Fuel enable signal

## Gear Branch

The Gear branch has provisions for two different functions; 1) connection to an E-STOPP electronic e-brake actuator, 2) connections to a Dakota Digital GSS-3000 Gear selector module. The circuits for both communicate with controllers under the dash in the cab through the rear harness bulkhead connector to the cab harness.

CIRCUIT	CIRCUIT LABEL	WIRE COLOR	AWG	CIRCUIT CURRENT RATING	FUSE NAME	FUSE VALUE
E-Brake actuator power	EBRAKE C	RED	16	8A	IGN/EFI/ECU	25A
E-Brake actuator ground	EBRAKE D	BLACK	16	8A	N/A	N/A
Gear selection signal 1	GEAR BLK	BLACK	18	8A	IGN/EFI/ECU	25A
Gear selection signal 2	GEAR GRN	GREEN	18	8A	IGN/EFI/ECU	25A
Gear selection signal 3	GEAR RED	RED	18	8A	IGN/EFI/ECU	25A

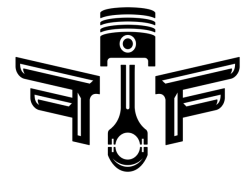

## Gear Split

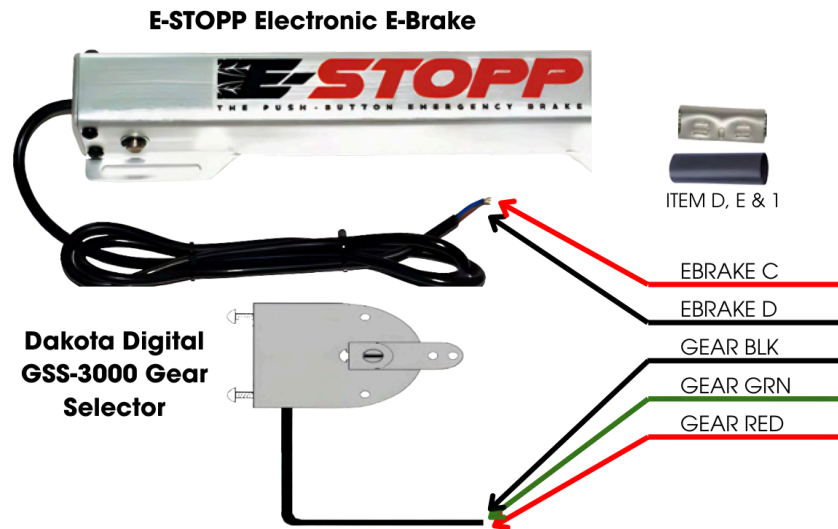

### TESTING Gear Indicator

- Dash gauge gear indicator, park, reverse, drive etc.

## Exhaust Branch 1 and 2

Exhaust branches 1 & 2 provide circuits for exhaust cutouts for passenger and driver side and a rear auxiliary lighting circuit. Most exhaust cutout are reversible DC motors. This means the two harness branches provided wires that will carry normal and reverse power connections. Included in this branch is a circuit for auxiliary rear lighting.

CIRCUIT	CIRCUIT LABEL	WIRE COLOR	AWG	CIRCUIT CURRENT RATING	FUSE NAME	FUSE VALUE
Ex Cut 1 signal to passenger side cutout	EX CUT 1	VIOLET	16	12A	POWER POINT	10A
Ex Cut 2 signal to passenger side cutout	EX CUT 2	BROWN	16	12A	POWER POINT	10A
Ex Cut 1 signal to driver side cutout	EX CUT 1	VIOLET	16	12A	POWER POINT	10A
Ex Cut 2 signal to driver side cutout	EX CUT 2	BROWN	16	12A	POWER POINT	10A
Auxiliary rear light 12V	AUX	ORANGE	16	12A	RADIO/AMP	20A
Auxiliary rear light circuit ground	AUX GND	BLACK	16	12A	N/A	N/A

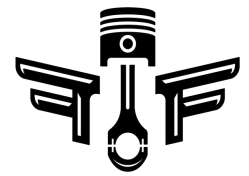

## Exhaust Split 1 and 2

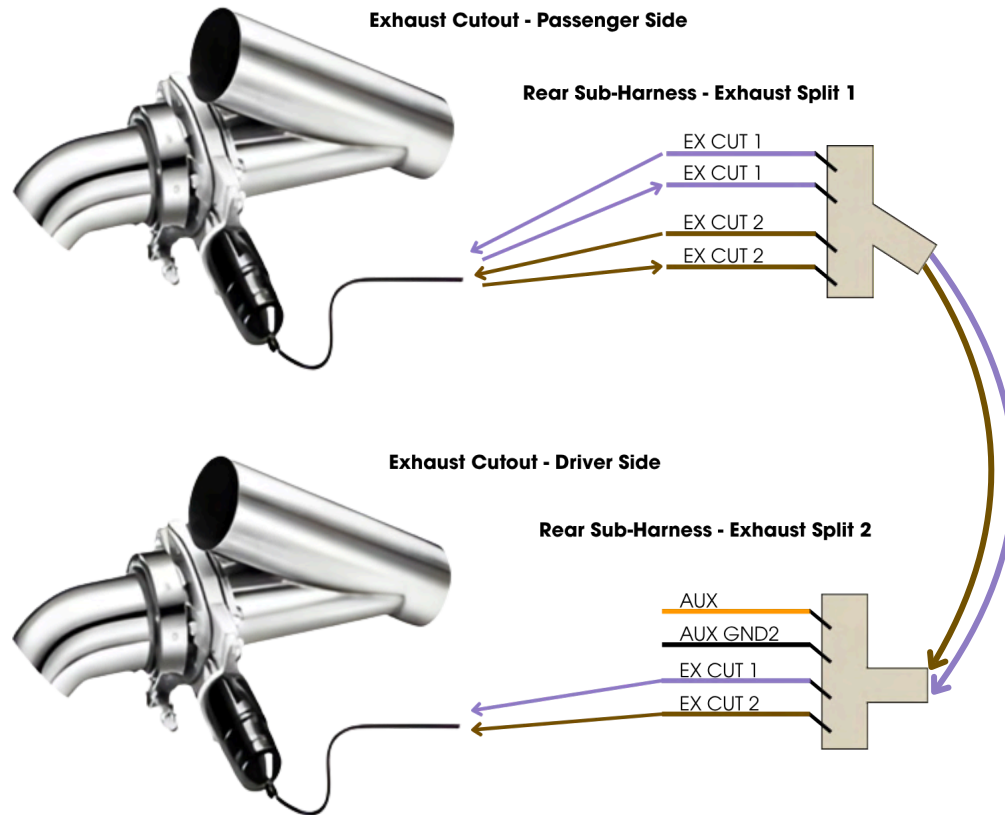

### TESTING Exhaust Cutouts & Transmission Fan

- Passenger exhaust butterfly    Driver exhaust butterfly  
 Transmission fan

## Rear Bulkhead Branch - Pinout

PIN	CIRCUIT	LABEL	I/O	WIRE COLOR	AWG	CURRENT RATING	FUSE NAME	FUSE VALUE
A	Tail Light	TAIL	0	BROWN	16	15A	HDLIGHT SW	15A
B	Tail Light	TAIL	0	BROWN	16	15A	HDLIGHT SW	15A
C	Backup Light	BACKUP	0	WHITE	16	15A	IGN ACCYS	10A
D	Left Rear Turn Signal	LR TURN	0	YELLOW	16	15A	FLASHER	15A
E	Right Rear Turn Signal	RR TURN	0	DARK GREEN	16	15A	FLASHER	15A
F	Rear Parking or Marker lights	PARK	0	BROWN	16	15A	HDLGHT SW	15A
G	Fuel Pressure Sensor Signal	FL PR BRN	I	BROWN	16	15A	VAPOR WORKS	25A
H	Fuel Pressure Sensor Power	FL PR GRAY	0	GRAY	18	8A	VAPOR WORKS	25A
J	Fuel Pressure Sensor Ground	FL PR BLK	0	BLACK	18	8A	N/A	N/A
K	Auxiliary Lighting	AUX	0	ORANGE	16	15A	RADIO/AMP	20A

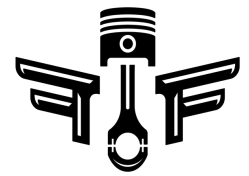

## Rear Bulkhead Branch - Pinout

PIN	CIRCUIT	LABEL	I/O	WIRE COLOR	AWG	CURRENT RATING	FUSE NAME	FUSE VALUE
L	Rear Auxiliary Lighting Ground	AUX GND2	0	BLACK	16	15A	N/A	N/A
M	Exhaust Cutout Signal 1	EX CUT 1	0	VIOLET	16	15A	POWER POINT	10A
N	Exhaust Cutout Signal 2	EX CUT 2	0	BROWN	16	15A	POWER POINT	10A
O	Electronic E-Brake Ground	EBRK D	0	BLACK	16	15A	N/A	N/A
P	Electronic E-Brake Power	EBRK C	0	RED	16	15A	IGN/EFI/ECU	25A
Q	Transmission cooler fan	TR FAN	I	YELLOW	16	15A	POWER POINT	10A
R	Transmission cooler fan gnd	TRAN FAN GND	I	BLACK	16	15A	POWER POINT	10A
S	Fuel Level Sensor Signal	FUEL LVL	I	GRAY	18	8A	VAPOR WORKS	25A
T	Fuel Level Sensor Signal	FUEL LVL GND	0	BLACK	18	8A	N/A	N/A
U	Gear Selection Signal (Black)	GEAR BLACK	I	BLACK	18	8A	IGN ACCYS	10A
V	Gear Selection Signal (Green)	GEAR GRN	I	DARK GREEN	18	8A	IGN ACCYS	10A
W	Gear Selection Signal (Red)	GEAR RED	I	RED	16	15A	IGN ACCYS	10A
X	NC							



# WARRANTY

Fat Fender Garage LLC. warrants the enclosed wiring harness from manufacturing defects and will repair or replace, at our discretion, the harness in the event of a manufacturing defect for a period of one year from the date of original purchase. The warranty applies to the original purchaser and is not transferable in any form.

This warranty covers normal consumer use, and does not cover damage due to shipping, failure resulting from improper installation, alteration, misuse, abuse, neglect of circuit specification, improper care and maintenance, or failure of 3<sup>rd</sup> party components.

Under any circumstance, the liability of Fat Fender Garage LLC. shall be limited to the original cost of the wiring harness kit paid and does not cover any labor related costs. Fat Fender Garage LLC. shall not be liable for any consequential or incidental damages which may occur as a result of the use of this harness kit.

# **FAT FENDER GARAGE**

4160 E Warner Rd STE 101

Gilbert, AZ 85296

480.621.6072

[fatfender.com](http://fatfender.com)